

93 NT

RECEPTION SETS R106, MKS 1 AND 2

TECHNICAL HANDBOOK - TECHNICAL DESCRIPTION

	<u>SUBJECT INDEX</u>	<u>Para</u>
INTRODUCTION		1 - 2
COMPLETE STATION		3
BRIEF ELECTRICAL DESCRIPTION		4 - 10
BRIEF MECHANICAL DESCRIPTION		11 - 14
CONTROLS		15
TECHNICAL DESCRIPTION		
GENERAL		16
Aerial and R.F. stages		17
Gain compensation		18 - 19
Frequency changer and local oscillator		20
Frequency drift		21
Crystal filter		22
I.F. stages		23
Detector and A.V.C.		24
A.F. stages		25 - 26
C.W. oscillator		27
S-meter		28
Differences between models		29
Power supply units		30 - 31
Bandspread coils		32

INDEX TO FIGURES

<u>Fig No.</u>		<u>Page</u>
1	Block diagram	3
2	Typical coil unit	4
3	Front-panel controls	5
4	Chassis, top view	7
5	Chassis, bottom view	7
6	Gain compensation, 14-30Mc/s band	8
7	S-meter circuit detail	10
8	S-meter sensitivity curve	10
1001	Reception set R106, Mk 1, circuit diagram	1005
1002	Individual coil units	1006
1003	Supply unit, rectifier, No. 5, circuit diagram	1007
1004	Supply unit, vibratory, No. 2, circuit diagram	1007

INDEX TO TABLES

1	Front panel controls	5 - 6
2	Bandspread coils	12
1001	Components	1001 - 1004
1002	Trimmer and padder capacitors	1004

INTRODUCTION

1. The R106 is a special purpose high grade superheterodyne receiver for the reception of C.W., M.C.W. and R.T. (A.M.) signals. It has very high stability and resetting accuracy.
2. There are four models of the R106 Mk 1 and one model of the Mk 2. Though most of these incorporate variable selectivity, optional A.V.C., variable pitch C.W. oscillator and signal strength meter, one model does not include crystal selectivity or signal strength meter. The main differences are listed in para 29.

COMPLETE STATION

3. The complete station includes the following items:

- (a) Reception set, R106, Mk 1 or Mk 2
- (b) Coil units as follows:-

- | | | | |
|-------------------|--------|-------------------|---------|
| (i) 50-100kc/s | Type J | (vi) 1.7-4Mc/s | Type JD |
| (ii) 100-200kc/s | Type H | (vii) 3.5-7.3Mc/s | Type JC |
| (iii) 180-430kc/s | Type G | (viii) 7-14Mc/s | Type JB |
| (iv) 480-960kc/s | Type F | (ix) 14-30Mc/s | Type JA |
| (v) 900-2050kc/s | Type E | | |

- (c) Supply unit, rectifier, No. 5
- (d) Supply unit, vibratory, No. 2
- (e) Receiver, headgear, double, C.H.R.
- (f) Batteries, secondary, portable, 6V, 85Ah.
- (g) Lamps, operator, No. 3
- (h) Connectors, twin, No. 24A.
- (j) Cases, spare valves, No. 4A

BRIEF ELECTRICAL DESCRIPTION

1. Fig 1 shows a block diagram of the receiver. The frequency range is covered in nine bands by separate plug-in coil units. When the crystal filter is not in use the I.F. bandwidth is 3.0kc/s at -6db. With the crystal in circuit the maximum selectivity is 200c/s at -6db.
2. Audio output may be fed to either headphones or a loudspeaker at will. The headphone impedance is 2000 Ω and the loudspeaker impedance is 7000 Ω . When the loudspeaker is disconnected from the set the output terminals at the rear of the chassis must be short-circuited.
3. The aerial input circuits are designed for coupling to a balanced or unbalanced transmission line of approximately 500 Ω impedance, but may be fed from a single wire aerial.
4. The receiver sensitivity over all bands is of the order of 2.0-3.0 microvolts for 1 watt output to a loudspeaker, with 30% modulation.
5. The receiver operates from either a 100 - 250V 50c/s A.C. supply using the supply unit, rectifier, No. 5 (see Tels K 220/5) or from a 6V D.C. battery supply, using the Supply unit, vibratory, No. 2. The power supplies required are H.T., 250V D.C. at 60mA, and L.T. 6.3V A.C. or D.C. at 3.5A.

9. Terminals are provided at the rear of the chassis for relay control of the receiver when required. These terminals must be short-circuited when not in use.

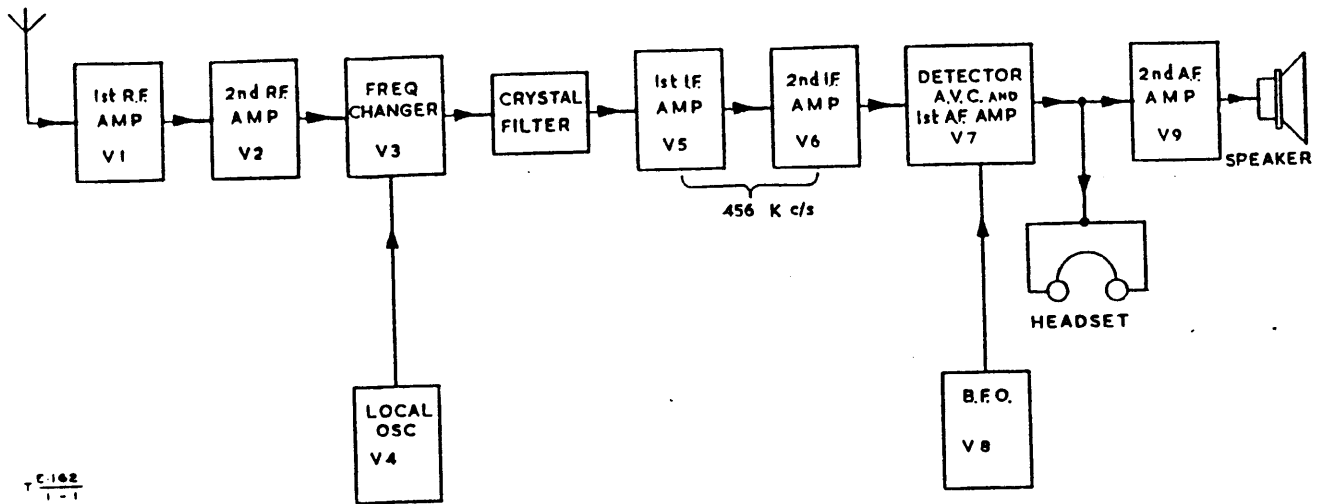

Fig 1 - Block diagram

10. The circuit differences between the Mk 1 and Mk 2 receivers are given in para 29. The changes in components are noted in Table 1001.

BRIEF MECHANICAL DESCRIPTION

11. The receiver normally is provided for table operation and is housed in a steel cabinet with hinged lid. All models can be provided for rack-mounting in which case only the chassis with a stronger front panel is supplied.

12. The physical dimensions of the receiver in its case, complete with one coil unit are as follows:-

Weight	32lbs	Width	17½ inches
Height	9 inches	Depth	12 inches

The dimensions of individual coil units are as follows:-

Weight	2lbs	Width	10½ inches
Height	2½ inches	Depth	5½ inches

13. The receiver is assembled on a steel chassis to which is attached a steel front panel. The coil units, (see Fig 2), comprise four separately screened cans which house the aerial, R.F., frequency-changer and oscillator coils together with their associated capacitors. All four sections are mounted on a panel, to which is attached a calibration chart, showing the relationship between dial reading and the frequency coverage of the unit. A table is also attached for the recording of station dial settings.

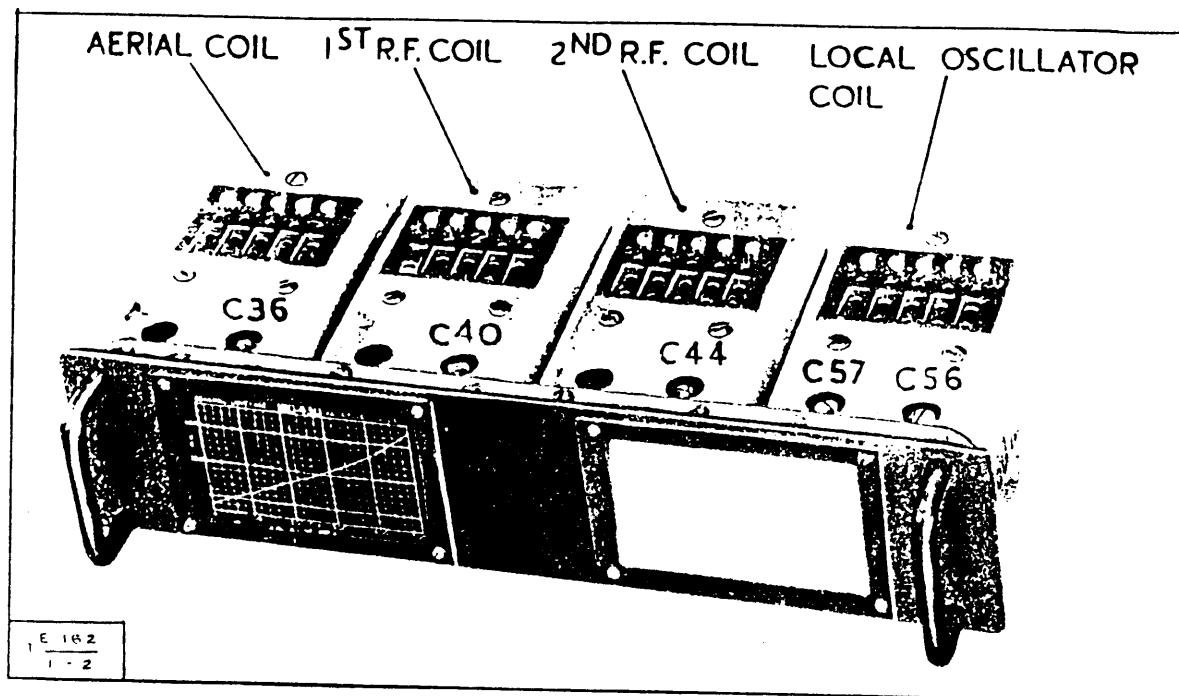

Fig 2 - Typical coil unit

14. The main tuning dial and drive mechanism is designed to provide the highest degree of re-setting and reading accuracy. An effective scale length of over 12 feet is obtained by the use of a 20 to 1 reduction gear. The dial is in two parts, an outer dial engraved with 50 divisions and having 5 equally spaced apertures and an inner dial geared to the outer but rotating on a separate eccentric bearing. The action is such that the numerals appearing through the aperture adjacent to the index indicate the number of divisions that have passed the index. In this way 500 divisions correspond to 10 revolutions of the dial for an angular movement of the driven spindle of 180° . Interpolation to one fifth of a division is easy and the dial may thus be read to one part in 2500. The split, spring-loaded, worm wheel reduction gearing is housed in a substantial die-cast casing. The tuning gang is of very rigid construction, each section being isolated from the case and having its own rotor earth contact.

CONTROLS
(see Fig 3)

15. With the exception of pre-set components all controls are mounted on the front panel, together with the S-meter, headphone output jack and pilot lamp. The designation, circuit reference and function of each control are given in Table 1. The aerial terminals are placed at the left-hand side of the chassis and are accessible through an opening in the side of the receiver case. The power leads are terminated in a four-pin plug, for use with either of the supply units mentioned in para 3.

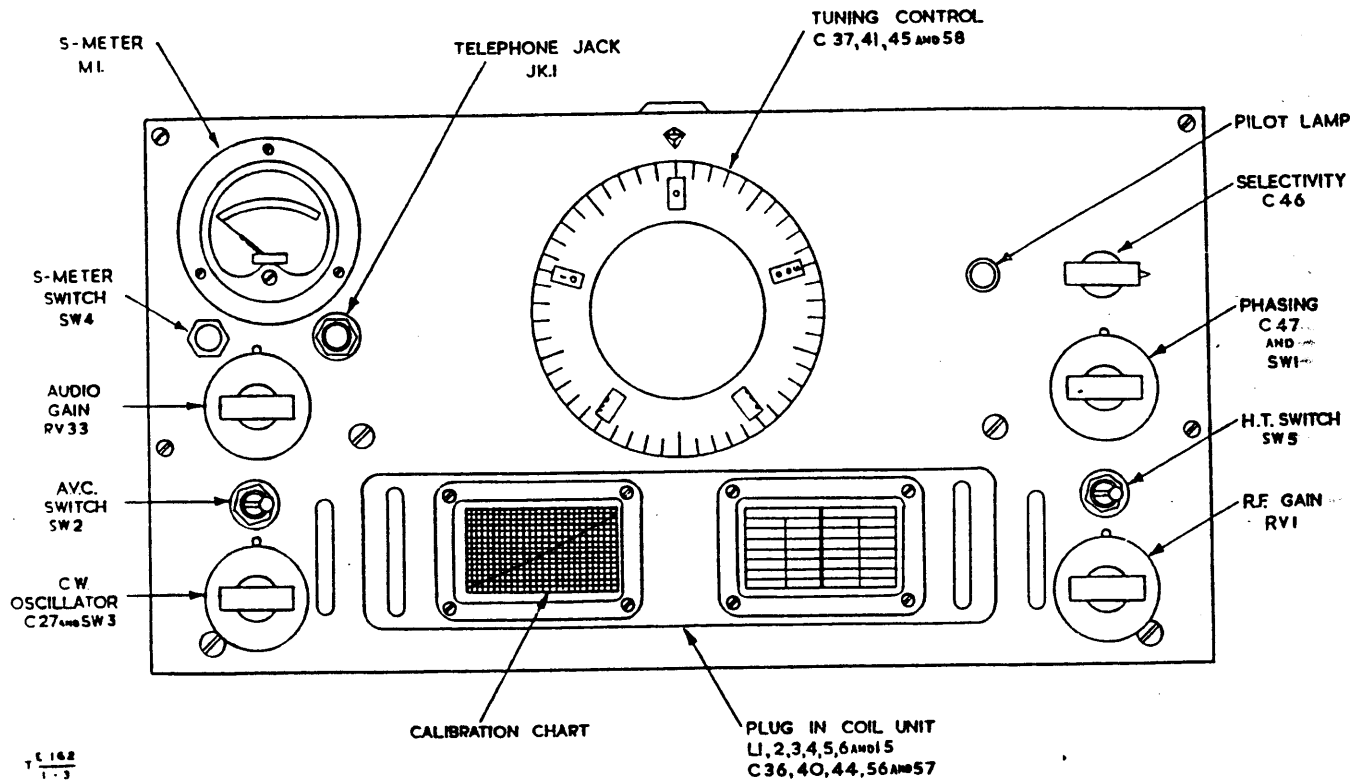

Fig 3 - Front panel controls

Table 1 - Front panel controls

Designation	Circuit reference	Function
Tuning control	C37; C41; C45; C58	Main tuning control. Clockwise rotation increases dial reading and frequency
H.T. switch	SW5	H.T. on/off toggle switch operation from left to right
Plug-in coil	L1 - L6 and L15 C36; C40; C44; C56; C57	R.F. and local oscillator tuned circuits
R.F. GAIN	RV1	Varies the gain of the 2nd R.F. and two I.F. stages, V2, V5 and V6

Table 1 - (contd)

Designation	Circuit reference	Function
AUDIO GAIN	RV33	A.F. volume control
Selectivity control	C46	Controls selectivity of I.F. stages when the crystal filter is in circuit. When crystal filter is not in use this control acts as a normal I.F. trimming capacitor
PHASING control and crystal filter switch	C47 SW1	Rotation from zero opens switch SW1 and brings crystal into operation. This control is then used for eliminating interfering signals
C.W. OSC. control and switch	C27 SW3	Clockwise rotation from zero closes switch in H.T. line to B.F.O., V8. This control varies the pitch of the beat note
A.V.C. switch	SW2	A change-over switch. Disconnects the grids of the R.F. and I.F. valves, V1, V2, V5 and V6 from the signal diode (Switch to left for A.V.C. ON)
S-meter switch	SW4	Normal on/off switch. Connects S-meter in circuit when required

TECHNICAL DESCRIPTION

General

16. The circuit diagram of the R106 Mk 1 is shown in Fig 1001. The aerial, R.F. and oscillator coil circuits shown are for the J type coil unit covering from 50-100kc/s. Fig 1002 shows the respective circuits for all the coil units. The circuit of the R106 Mk 2 is similar to the Mk 1 except as noted in Table 1001 and Fig 1001. Top and bottom views of the chassis are shown in Figs 4 and 5.

Aerial and R.F. stages

17. V1 and V2 are conventional R.F. amplifiers. The aerial is transformer coupled to the grid of V1 on all ranges by L1 and L2. V1 and V2 are transformer coupled by L3 and L4. A.V.C. bias is fed to the two stages via R28 and R31 respectively.

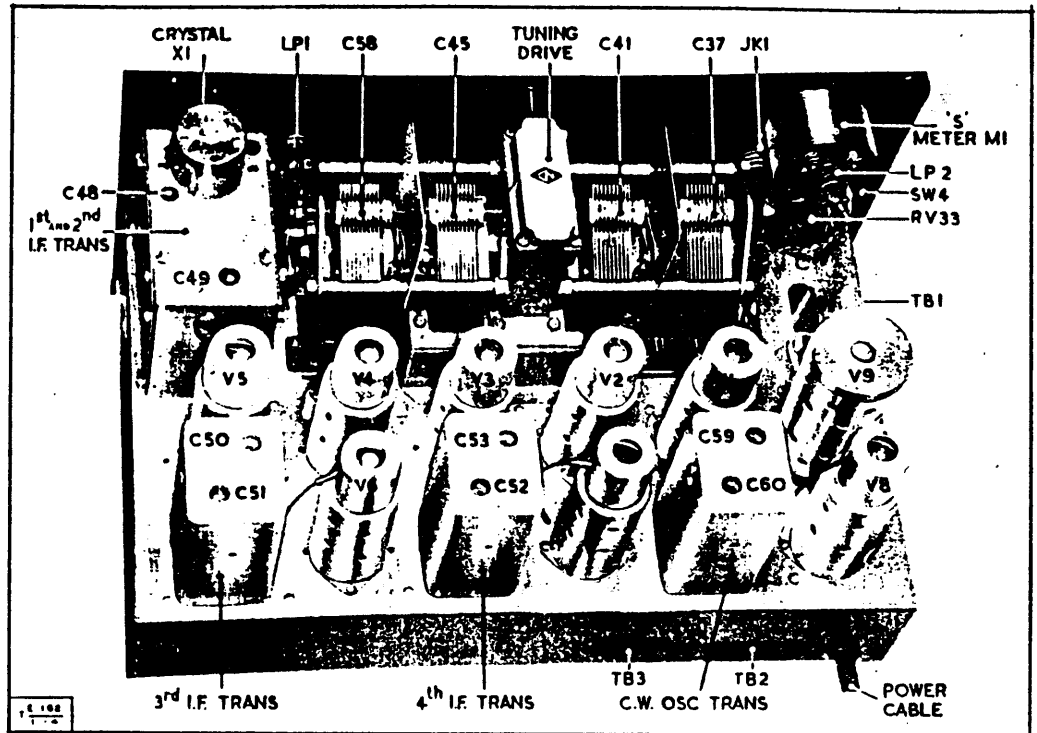

Fig 4 - Chassis, top view

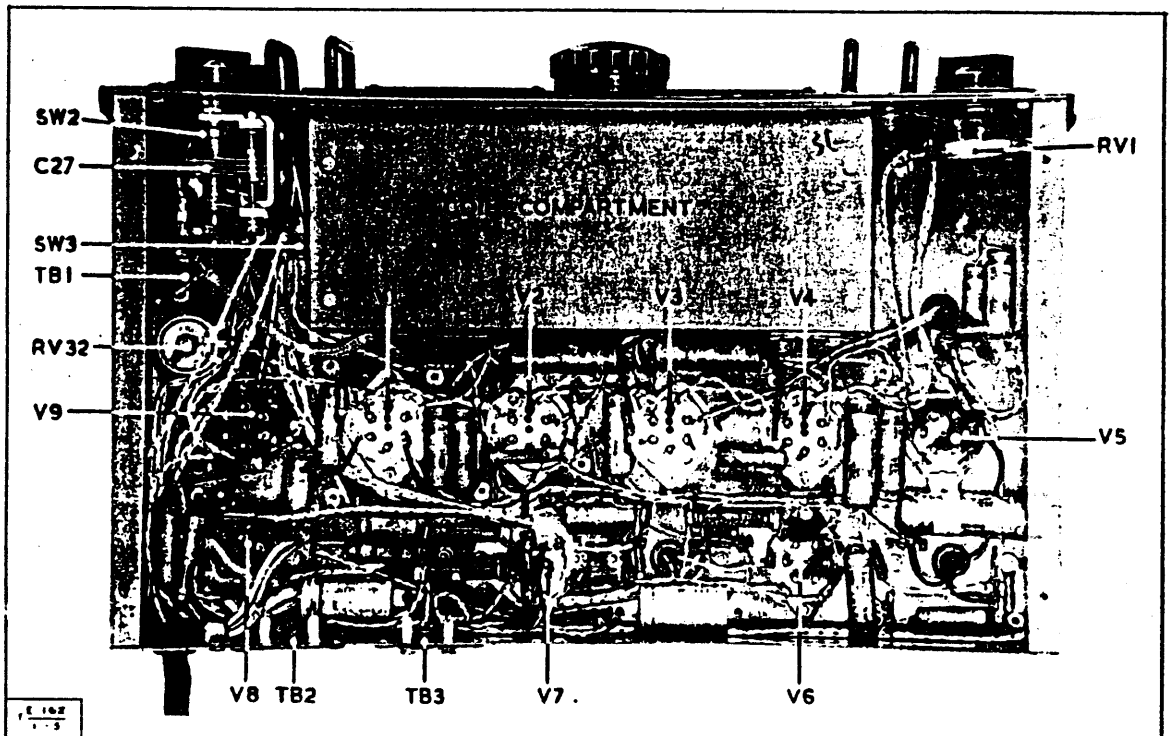

Fig 5 -- Chassis, bottom view

Gain compensation

18. The R.F. stages are designed to ensure uniform gain throughout the tuning range. High inductance primary coils are used in the interstage R.F. transformers. The coils are designed so that the primary circuit, as a whole, resonates broadly at a frequency outside the low frequency limit of the coil unit. The primary circuit therefore shows increasing impedance as the tuning of the receiver approaches the low frequency end of the band, thus compensating for the decreasing impedance of the secondary.

19. In the 14-30Mc/s band a different arrangement has been employed. The inter-stage R.F. transformer has three windings (see Fig 6). The primary winding is closely coupled to the tuned secondary, being interwound with it and having the same number of turns. A grid winding which consists of a large number of turns of fine wire is also closely coupled to the secondary. This grid winding is resonant outside the low frequency end of the band and compensates for variations in the impedance of the tuned circuit. Gain compensation is not employed on the 50-100kc/s band.

Frequency-changer and local oscillator

20. V2 is coupled to the frequency changer, V3, by the R.F. transformer L5 and L6. A separate local oscillator employing a Hartley circuit is used. The output from the local oscillator, V4, is fed from the cathode via C7 to the screen of V3. The frequency-changer operates with fixed cathode bias and A.V.C. is not applied.

Frequency drift

21. Frequency drift is minimised by employing high stability components in the tuned circuits and by minimising the effects of any temperature change. Drift due to gradual changes in room temperature is reduced by the use of air dielectric trimmers and tuning capacitors and coil formers having a low temperature coefficient of expansion. The R.F. coil unit is plugged into the set under the chassis to minimise heating from the valves. The temperature in the receiver is also kept down by using a separate power supply unit and a well ventilated cabinet.

Crystal filter

22. The crystal filter circuit is conventional in design and operates at the nominal I.F. frequency of 456Kc/s. Two controls are provided together with a switch ganged to the phasing control for short-circuiting the crystal when it is not required. With

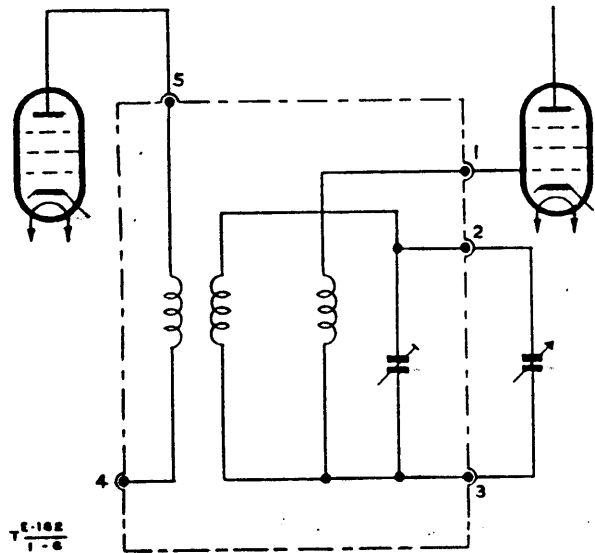

Fig 6 - Gain compensation,
14-30Mc/s band

the crystal in circuit, the bandwidth in the broad position of the selectivity control, is approximately 2.5kc/s and in the sharp position approximately 200c/s, at 6db down. With the crystal in circuit the phasing control can be adjusted to suppress any one interfering signal differing from the desired signal by 300c/s or more. The bridge circuit component values are such that balance is obtained with the phasing control set at approximately the centre of its capacity range. When the crystal is short-circuited by turning the phasing control fully anti-clockwise to zero, the selectivity control acts as a normal I.F. trimmer and should be set for maximum sensitivity.

I.F. stages

23. The output from the crystal unit is matched to the first I.F. stage, V5, by the tapping on L9. The two I.F. stages, in addition to cathode biasing via R4 and R9 respectively, have A.V.C. applied to their grids through R3 and R8. The gain of the two I.F. stages together with the second R.F. stage is manually controlled by the R.F. gain-control, RV1.

Detector and A.V.C.

24. The detector and A.V.C. circuits employ the first diode of V7. A.V.C. is fed via R19 to the filter circuits of the controlled valves when the A.V.C. switch is ON. When the A.V.C. is switched OFF, the mean grid bias of the controlled valves is maintained by the second diode, at approximately the same potential as that existing under no signal conditions with A.V.C. ON. The by-pass capacitor, C15, in the second diode circuit, removes any stray signal pickup or feedback which could produce partial A.V.C. with the switch in the OFF position.

A.F. stages

25. The audio amplifier section of V7 is a pentode in the Mk 1 receiver and a triode in the Mk 2 receiver. The anode load R18 and V9 cathode resistor, R25, differ in the two receivers due to different valve characteristics. R16 and R17 are omitted in the Mk 2.

26. The A.F. output from V7 is resistance-capacitance coupled to the grid of V9 for loudspeaker operation. When the headphone plug is inserted in JK1, C18 is disconnected from the grid of V9, which is then earthed through the jack, JK1.

C.W. oscillator

27. The C.W. oscillator is provided with a variable pitch control on the front panel. This control also operates the switch SW3, in the H.T. line to the valve. Capacitor C20 prevents feedback via the heater circuit.

S-meter

28. The S-meter operates in a bridge circuit (see Fig 7). It is calibrated in S-units and db above S9. The bridge circuit is initially balanced by R32, so that the meter deflection is zero under no signal conditions with the R.F. gain control set to 9.5. Fig 8 shows the relation between meter readings and the actual signal input to the receiver in microvolts. It will be seen from Fig 8 that each S-unit is equal to a change of approximately 4db. The 40db range above S9 level is used for comparative checks on extremely strong signals.

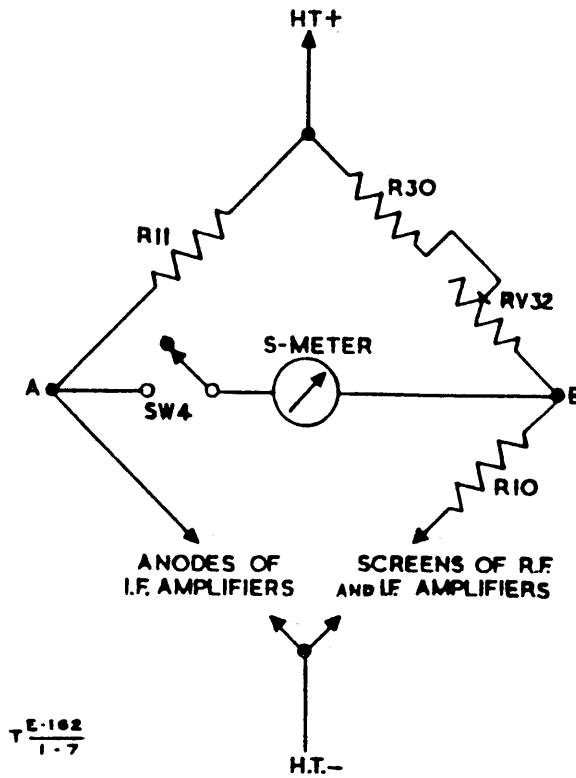

Fig 7 - S-meter, circuit detail

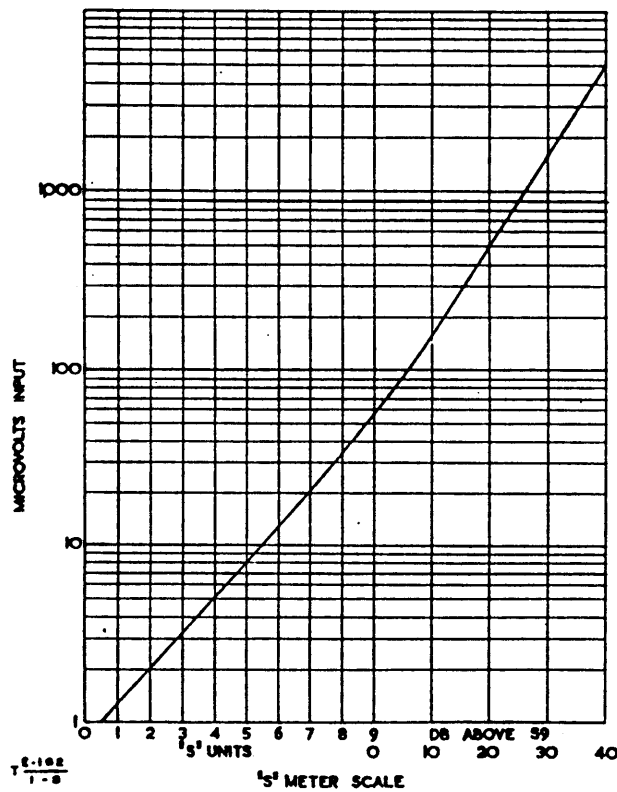

Fig 8 - S-meter, sensitivity curve

Differences between models

29. The foregoing description covers all models, the main differences being listed below:-

R106, Mk 1

- (a) H.R.O. Senior: This is the original model which is complete with amateur bandspread (see para 32), crystal filter and S-meter
- (b) H.R.O. Junior: This is similar to H.R.O. Senior but without the special facilities enumerated in (a) above
- (c) H.R.O.-M: This is similar to the H.R.O. Senior, less bandspread but is provided with a plug-in crystal gate
- (d) H.R.O.-MX: Similar to H.R.O.-M but with built-in crystal gate.

R106, Mk 2

- (a) H.R.O.-5: This is similar to H.R.O.-Mx but uses metal valves instead of glass. (see para 25 and Table 1001 for component changes)

POWER SUPPLY UNITS
(see Figs 1003 and 1004)

30. The Supply unit rectifier, No. 5 (Fig 1003) consists of a standard full-wave rectifier circuit using an indirectly heated rectifier, V1 (CV 1865). The smoothing circuit uses a capacitor input filter C3, L1, followed by a further stage consisting of C4A, C4B and L2. An R.F. choke, L3, is included in the output lead. The H.T. supply is fused in the negative return lead by FS1. (250mA). The primary circuit is tapped for mains supplies from 100-170W and 200-250V A.C. R.F. bypass capacitor C1 and C2 filter the primary circuit. The indicator lamp, LP1, is wired across the L.T. circuit.

31. The Supply unit, vibratory, No. 2 (Fig 1004) comprises a non-synchronous vibrator driven from a 6V battery through an R.F. input filter and spark suppression circuit. The indicator lamp, LP1, is wired into the input circuit. The chopped D.C. from the vibrator is stepped up by T2 and fed to the full-wave cold-cathode rectifier, V1 (CV 692). Comprehensive smoothing circuits are provided to remove traces of interference from the vibrator circuits.

BANDSPREAD COILS

32. Some receivers of either Mk may be equipped with a set of coils giving a bandspread facility. Table 2 shows the frequency coverage of these coils. It will be noted that a portion of the range in each case is extended to cover almost the whole of the tuning dial scale. These coil-sets are aligned for a particular receiver and differ further in that the coil-set for a receiver with metal valves (Mk 2) will not operate with a receiver using glass valves (Mk 1) without realignment.

Table 2 - Bandsread coils

Coil-set	General coverage	Bandsread	Dial
A	14 - 30Mc/s	28 - 29.7Mc/s	50 - 450
B	7 - 14.4Mc/s	14 - 14.4Mc/s	50 - 450
C	3.5 - 7.3Mc/s	7 - 7.3Mc/s	50 - 450
D	1.7 - 4Mc/s	3.5 - 4Mc/s	50 - 450

Note: The next page is Page 1C01

Table 1001 - Components

Circuit ref	Value	Tolerance and rating	Type	Location
RESISTORS				
RV1	10k Ω		1.1/2W	Variable
R2	5k Ω	$\pm 10\%$	1/2W	C3
R3	500k Ω	$\pm 10\%$	1/2W	E4
R4	300 Ω	$\pm 10\%$	1/2W	G4
R5	50k Ω	$\pm 10\%$	1/2W	H4
R6	100k Ω	$\pm 10\%$	1/2W	D3
R7	100k Ω	$\pm 10\%$	1/2W	E2
R8	500k Ω	$\pm 10\%$	1/2W	D1
R9	2.2k Ω	$\pm 10\%$	1/2W	J4
R10	15k Ω	$\pm 10\%$	1W	J4
R11	250 Ω	$\pm 10\%$	1/2W	K6
R12	500k Ω	$\pm 10\%$	1/2W	L6
R13	50k Ω	$\pm 10\%$	1/2W	L4
R14	250k Ω	$\pm 10\%$	1/2W	L4
R15	30k Ω	$\pm 10\%$	1W	K5
R16 Mk 1	20k Ω	$\pm 10\%$	1/2W	M4
R16 Mk 2	Omitted			K6
R17 Mk 1	100k Ω	$\pm 10\%$	1W	L4
R17 Mk 2	Omitted			L6
R18	100k Ω	$\pm 10\%$	1W	L6
R18 Mk 2	50k Ω	$\pm 10\%$	1W	I6
R19	500k Ω	$\pm 10\%$	1/2W	K4
R20	800 Ω	$\pm 10\%$	1/2W	L4
R21	60 Ω	$\pm 10\%$	2W	O3
R22	100k Ω	$\pm 10\%$	1/2W	M3
R23	250k Ω	$\pm 10\%$	1/2W	M3
R24	100k Ω	$\pm 10\%$	1/2W	M2
R25 Mk 1	500 Ω	$\pm 10\%$	1W	N4
R25 Mk 2	300 Ω	$\pm 10\%$	1W	H4
R26	500k Ω	$\pm 10\%$	1/2W	N4
R27	300 Ω	$\pm 10\%$	1/2W	B4
R28	500k Ω	$\pm 10\%$	1/2W	B4
R29	300 Ω	$\pm 10\%$	1/2W	D4
R30	2k Ω	$\pm 10\%$	1/2W	L6
R31	500k Ω	$\pm 10\%$	1/2W	C4
RV32	1k Ω		1W	Variable
RV33	500k Ω	$\pm 20\%$	2W	Variable
R34	50k Ω	$\pm 10\%$	1/2W	K4
R35	20k Ω	$\pm 10\%$	1/2W	L2
				D2

Note: R9 varies with individual receivers between 1k Ω and 5k Ω

Table 1001 - (contd.)

Circuit ref	Value	Tolerance and rating	Type	Location
CAPACITORS				
C1	0.1 μ F	+20% -10%	400V D.C. wkg	H4
C2	0.01 μ F	+20% -10%	600V D.C. wkg	H4
C3	0.1 μ F	+20% -10%	400V D.C. wkg	F4
J4	0.1 μ F	+20% -10%	600V D.C. wkg	C6
C5	0.1 μ F	+20% -10%	600V D.C. wkg	E1
C6	0.1 μ F	+20% -10%	400V D.C. wkg	H4
C7	0.01 μ F	+20% -10%	600V D.C. wkg	E2
C8	0.25 μ F	+20% -10%	600V D.C. wkg	J4
C9	0.01 μ F	+20% -10%	600V D.C. wkg	J4
C10	0.1 μ F	+20% -10%	400V D.C. wkg	J4
C11	10 μ F	+15% - 0%	50V D.C. wkg	M4
C12	100pF	+5%	500V D.C. wkg	L4
C13	250pF	+10%	500V D.C. wkg	L5
C14	0.1 μ F	+20% -10%	400V D.C. wkg	K4
C15	0.01 μ F	+20% -10%	600V D.C. wkg	M4
C16	500pF	+10%	1000V D.C. wkg	M4
C17	0.1 μ F	+20% -10%	400V D.C. wkg	D4
C18	0.1 μ F	+20% -10%	600V D.C. wkg	N5
C19	10 μ F	+15% - 0%	50V D.C. wkg	O4
C20	0.1 μ F	+20% -10%	400V D.C. wkg	M1
C21	0.1 μ F	+20% -10%	400V D.C. wkg	M1
C22	0.1 μ F	+20% -10%	400V D.C. wkg	B4
C23	0.1 μ F	+20% -10%	400V D.C. wkg	B6
C24	0.01 μ F	+20% -10%	600V D.C. wkg	B4
C25	0.1 μ F	+20% -10%	600V D.C. wkg	C6
C26	0.01 μ F	+20% -10%	600V D.C. wkg	C4

Table 1001 - (contd)

Circuit ref	Value	Tolerance and rating	Type	Location
C27	5-35pF		Variable	M1
C28	0.01μF	+20% 600V D.C. wkcg -10%		N4
C29	0.001μF	+10% 500V D.C. wkcg		L2
C30	100pF	+5% 500V D.C. wkcg		D2
C31	100pF	+5% 500V D.C. wkcg		F5
C32	100pF	+5% 500V D.C. wkcg		F5
C33	2pF	+50% 400V D.C. wkcg		M3
C36	see Table 1002			A5
C37	12-225pF		Variable gang	B4
C40	see Table 1002			C5
C41	12-225pF		Variable gang	C4
C42	see Table 1002			E5
C45	12-225pF		Variable gang	E4
C45	100pF		Variable	G5
C47	10pF		Variable	G5
C48	3-30pF		Trimmer	G5
C49	6-85pF		Trimmer	H5
C50	6-85pF		Trimmer	H5
C51	6-85pF		Trimmer	J5
C52	6-85pF		Trimmer	K5
C53	6-85pF		Trimmer	K5
C56	see Table 1002			C2
C57	see Table 1002			C2
C58	12-225pF		Variable gang	C1
C59	6-85pF		Trimmer	L2
C60	6-85pF		Trimmer	L2
C61	50pF	+5% 500V D.C.		C2
C62	100pF	+5% 500V D.C.	1002 type	G4
C63	350pF	+10% 500V D.C.	1002 type	F4
C64	450pF	+10% 500V D.C.	1002 type	E4
C65	880pF	+10% 500V D.C.	1002 type	JD4
C66	1600pF	+10% 500V D.C.	1002 type	JC4
C67	2600pF	+10% 500V D.C.	1002 type	JB4
C68	40pF	+5% 500V D.C.	1002 type	JA1
C69	1200pF	+10% 500V D.C.	1002 type	JA1
C70	850pF	+10% 500V D.C.	1002 type	JAL

Table 1001 - (contd)

Circuit ref	Type Mk 1	Type Mk 2	Location
VALVES			
V1	CV1900 (6D6)	CV1942 (6K7)	B5
V2	CV1900 (6D6)	CV1942 (6K7)	D5
V3	CV585 (6C6)	CV1936 (6J7)	E5
V4	CV585 (6C6)	CV1936 (6J7)	D2
V5	CV1900 (6D6)	CV1942 (6K7)	H5
V6	CV1900 (6D6)	CV1942 (6K7)	J5
V7	CV1891 (6B7)	CV1990 (6SQ7)	L5
V8	CV585 (6C6)	CV1936 (6J7)	M2
V9	CV609 (42)	CV511 (6V6GT/G)	N5

SWITCHES

SW1	Crystal filter switch	G5
SW2	A.G.C. switch (toggle)	L3
SW3	C.W. oscillator H.T. switch (toggle)	M3
SW4	S-meter switch (push-pull)	L6
SW5	H.T. switch (toggle)	O6

Table 1002 - Trimmer and padder capacitors

Coil set	Frequency range	C36	C40	C44	C56	C57
JA	14 - 30Mc/s	5-28pF	5-28pF	5-28pF	5-28pF	-
JB	7 - 14.4Mc/s	5-28pF	5-28pF	5-28pF	6-38pF	-
JC	3.5 - 7.3Mc/s	5-28pF	5-28pF	5-28pF	5-28pF	-
JD	1.7 - 4Mc/s	5-28pF	5-28pF	5-28pF	5-28pF	-
E	900 - 2050kc/s	5-28pF	5-28pF	5-28pF	5-28pF	6-38pF
F	480 - 960kc/s	6-38pF	6-38pF	6-38pF	7-56pF	6-38pF
G	180 - 430kc/s	5-28pF	5-28pF	5-28pF	5-28pF	6-38pF
H	100 - 200kc/s	6-38pF	6-38pF	6-38pF	8.5-75pF	10-97pF
J	50 - 100kc/s	6.5-45pF	6.5-45pF	6.5-45pF	8.5-75pF	8.5-75pF

6

5

4

3

2

1

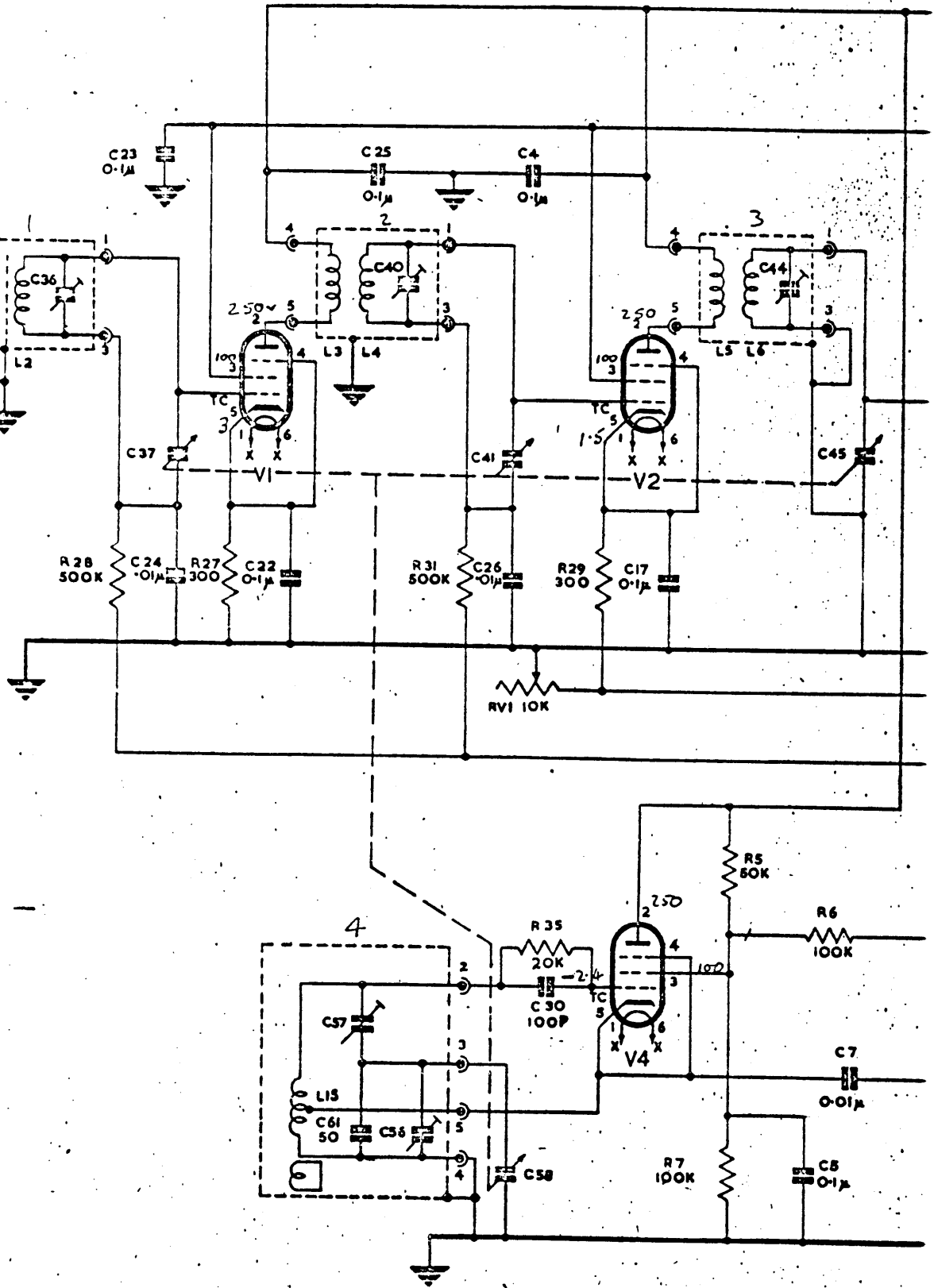

RESTRICTED

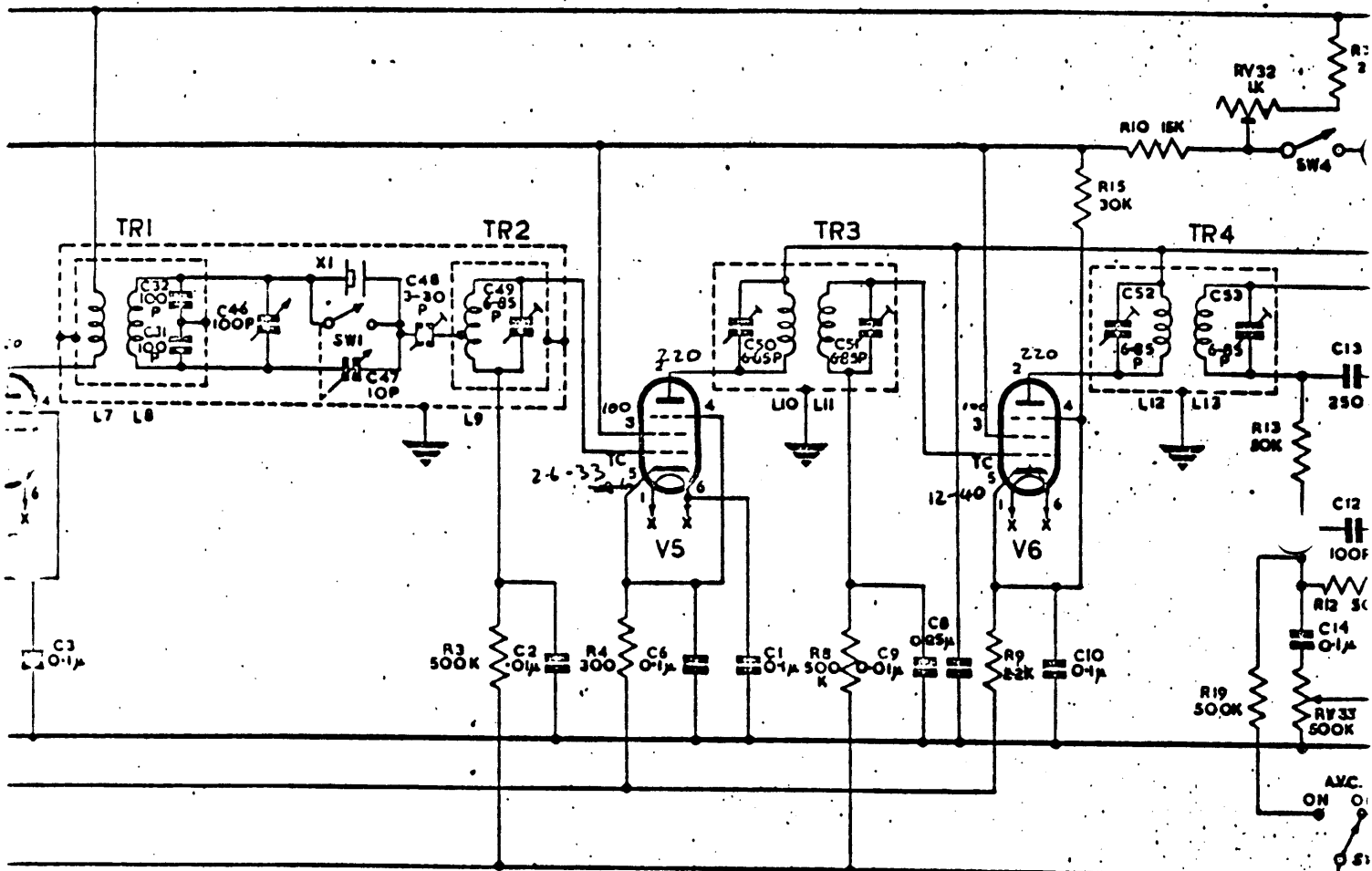

RESISTOR VALUES IN OHMS
 CAPACITOR VALUES IN FARADS
 SHOWN WITH COIL UNIT (50-100KΩ)

- | | |
|-----------------------|-----------------|
| MK I | MK II |
| V5, V6 = 6D6 (CV1900) | 6K7 (CV1942) |
| 6C6 (CV585) | 6J7 (CV1936) |
| 6B7 (CV1091) | 6SQ7 (CV1990) |
| 4Z (CV609) | 6V6GT/G (CV311) |
| 20K | OMITTED |
| 100K | OMITTED |
| 100K | 50K |
| 500 | 300 |

VALVE PIN CONNECTIONS MK II RECEIVER

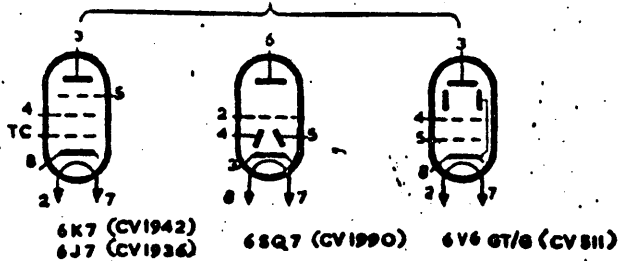

F | G | H | J | K |

Fig. 1001—Reception set R106, Mk I, circuit diagram

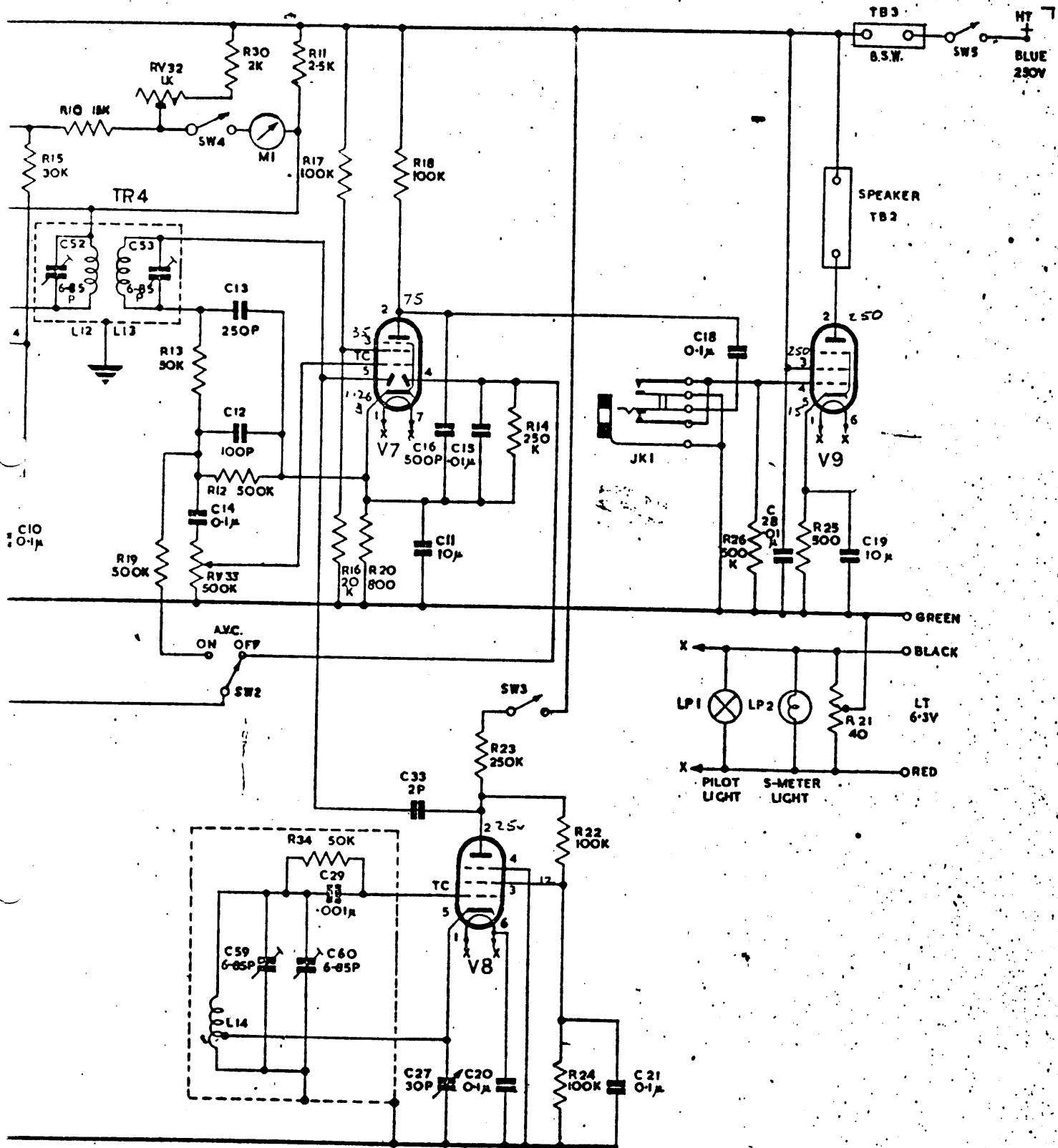

COIL STAGE	FREQUENCY 50-100 Kc/s TYPE J	FREQUENCY 100-200 Kc/s TYPE H	FREQUENCY 300-400 Kc/s TYPE G	FREQUENCY 400-600 Kc/s TYPE F	FREQUENCY 0.5-2.0 Mc/s TYPE E	FREQUENCY 1.7-4.0 Mc/s TYPE D	FREQUENCY 3.5-7.0 Mc/s TYPE C	FREQUENCY 7.0-14.4 Mc/s TYPE B	FREQUENCY 14.0-30.0 Mc/s TYPE A
AERIAL	AE COIL 1 	AE COIL 1 	AE COIL 1 	AE COIL 1 	AE COIL 1 	AE COIL 1 	AE COIL 1 	AE COIL 1 	AE COIL 1
FIRST R.F. TRANSFORMER	HF1 2 	HF1 2 	HF1 2 	HF1 2 	HF1 2 	HF1 2 	HF1 2 	HF1 2 	HF1 2
SECOND R.F. TRANSFORMER	HF2 3 	HF2 3 	HF2 3 	HF2 3 	HF2 3 	HF2 3 	HF2 3 	HF2 3 	HF2 3
LOCAL OSCILLATOR	OSC 4 	OSC 4 	OSC 4 	OSC 4 	OSC 4 	OSC 4 	OSC 4 	OSC 4 	OSC 4

FOR VALUES OF C36,40,43,56,57 SEE TABLE NO. 2

Fig 1002 - Individual coil units

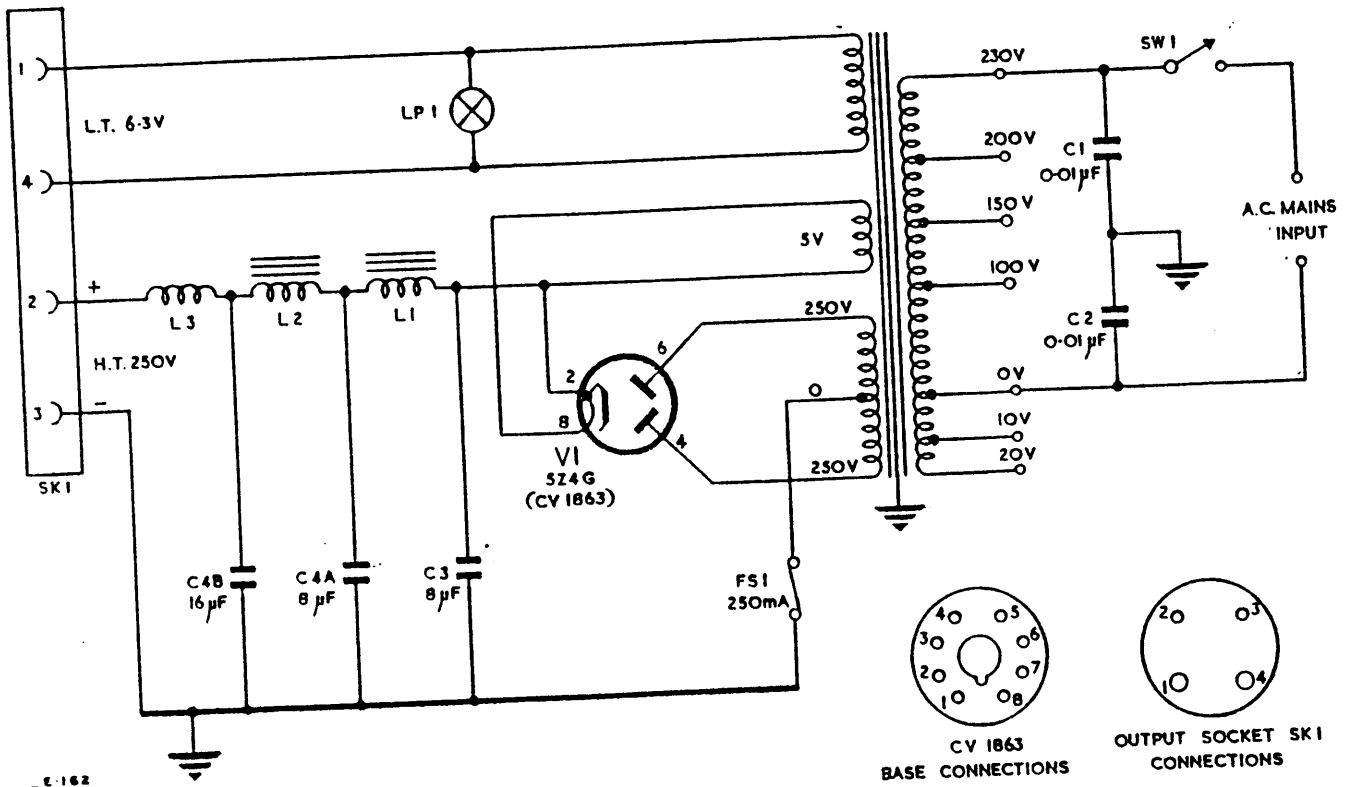

E-162
1-1003

Fig 1003 - Supply unit, rectifier, No. 5, circuit diagram

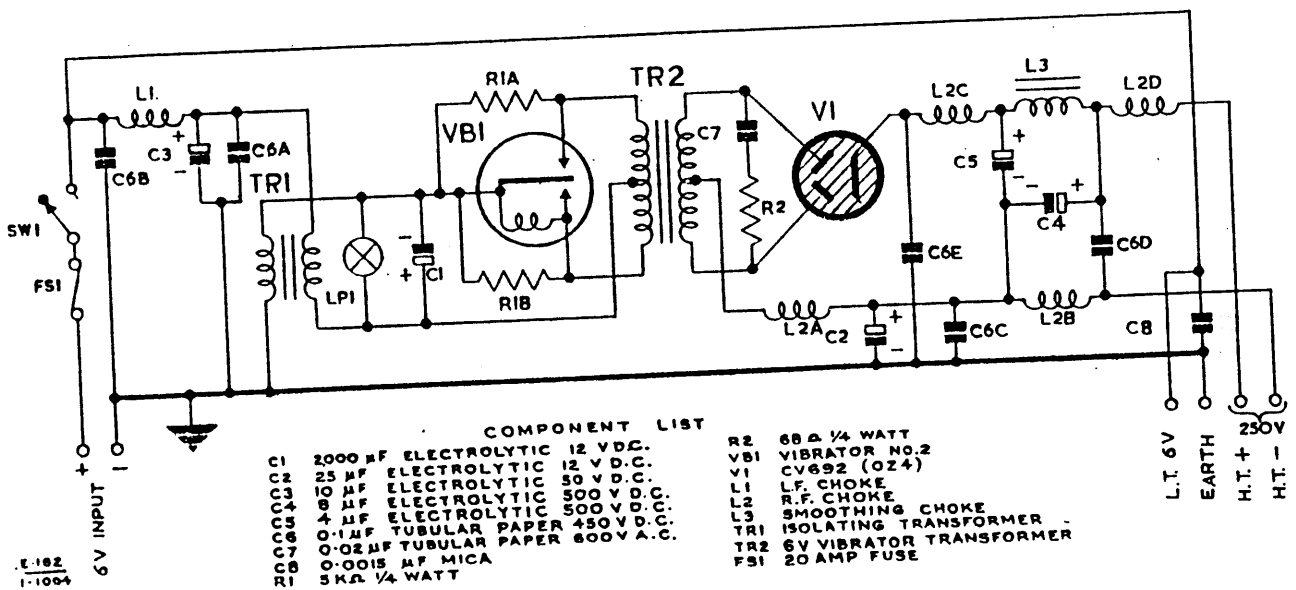

E-162
1-1004

Fig 1004 - Supply unit, vibratory, No. 2, circuit diagram

COMPONENT LIST

C1	2000 μF ELECTROLYTIC 12 V.D.C.	R2	68 Ω ¼ WATT
C2	25 μF ELECTROLYTIC 12 V.D.C.	VBI	VIBRATOR NO.2
C3	10 μF ELECTROLYTIC 50 V.D.C.	V1	CV692 (OZ4)
C4	8 μF ELECTROLYTIC 500 V.D.C.	L1	L.F. CHOKE
C5	4 μF ELECTROLYTIC 500 V.D.C.	L2	R.F. CHOKE
C6	0.1 μF TUBULAR PAPER 450 V.D.C.	L3	SMOOTHING CHOKE
C7	0.02 μF TUBULAR PAPER 800 V.A.C.	TR1	ISOLATING TRANSFORMER
C8	0.0015 μF MICA	TR2	6V VIBRATOR TRANSFORMER
R1	5kΩ ¼ WATT	FS1	20 AMP FUSE

L.T.	6V	250V
EARTH		
H.T.	+	-
H.T.		

RECEPTION SETS R106, MKS 1 AND 2

TECHNICAL HANDBOOK - UNIT REPAIRS

GENERAL

1. No adjustments, except those detailed in this Regulation, will be made to the receiver by unit repair sections since the accuracy and sensitivity of the set depend on very accurate alignment and adjustment carried out in Base workshops.
2. For technical description, circuit diagrams and component tables, refer to Tels E 162.

SETTING-UP INSTRUCTIONS

3. The receiver is set up for normal operation as follows:-
 - (a) Ensure that the appropriate power supply unit is connected to the set, but it is at this stage switched OFF. For operation from 100-250V A.C. mains use the Supply unit, rectifier, No. 5, and for 6V D.C. battery operation use the Supply unit, vibratory, No. 2.
 - (b) Select the appropriate plug-in coil unit and insert it in position in the receiver (see para 3, Tels E 162).
 - (c) Connect the loudspeaker, if required, to the terminals at the rear of the set. If a loudspeaker is not used, these terminals must be short-circuited. Do not stand the loudspeaker on the receiver cabinet.
 - (d) The aerial terminals are located on the left-hand side of the receiver. If a single wire aerial or unbalanced feeder line is to be used, connect the aerial or feeder lead to the terminal nearest the front panel and connect the flexible earth lead to the other terminal. If a balanced transmission line is used, connect it to both terminals and in this case, the flexible earth lead is not used.
 - (e) Switch on the P.S.U. and switch on the H.T. to the receiver at SW5; (terminals BSW at the back must be short-circuited if the receiver is not to be used on a relay system).
 - (f) Tune the receiver by setting the dial to the scale reading given by the calibration chart on the coil unit for the frequency desired.
 - (g) Set the R.F. GAIN, RV1 and AUDIO GAIN, RV33 to give the required output level.
 - (h) The selectivity control, C46, when used with the crystal filter in circuit gives minimum selectivity in the vertical position. Selectivity is increased by rotating the knob either way. When the crystal filter is not in use, this control acts as an I.F. trimmer, and should be set to give maximum volume.

- (j) The PHASING control and crystal filter switch is used when receiving C.W. or H.C.W. In position 0 the crystal is short-circuited; in any other position the PHASING control may be used to eliminate any one interfering station more than 300c/s away from the required station.
- (k) The C.W. OSC. switch and control is used on C.W. to give an audible note, or on H.C.W. to assist in the location of a weak station. Rotating the control varies the pitch of the beat note.
- (l) The A.V.C. switch, SW2, may be used as required on R.T. or H.C.W. A.V.C. should not be used when the C.W. oscillator is in operation.

4. If it is desired to change the coil unit while the set is in operation, the H.T. must first be switched OFF at switch SW5.

ROUTINE TECHNICAL MAINTENANCE

Receiver

5. Daily:-

- (a) Check all controls for smoothness of action and freedom from backlash, especially the main tuning control. If the tuning control is defective, report immediately. Do not remove the wormwheel casing.
- (b) Clean the outside of the case. Examine external cables and plugs ensuring that these are in good condition and that all connections are tight.

6. Monthly:-

- (a) Remove the receiver from its case and remove the baseplate. Brush out all dust, being careful not to disturb any R.F. wiring or damage the vanes of the tuning capacitor. Remove the coil unit and clean out the coil compartment. If a portable air blower is available, use this in preference to a brush for cleaning the equipment.
- (b) Check all valves for loose top caps and bases, replacing any that are defective. Ensure that all valve pins make good contact with their sockets. Test all valves.
- (c) Examine all soldered joints, repairing any that are loose or broken. Check that all components are firmly mounted and that no fixing nuts or screws are loose.
- (d) Ensure that the contacts on all coil units and in the coil compartment are clean and make good contact with each coil unit in position in turn. Clean the sliding earth contacts on each gang of the tuning capacitor and lubricate with a trace of grease PX 7.
- (e) Check the calibration of the receiver on all bands, using either the Wavemeter, class D, or the Frequency meter, SCR 211. If re-calibration or re-alignment is necessary, the set must be returned to Base workshops.

Power supply unit7. Monthly:-

Remove the P.S.U. from its case and clean it thoroughly. Check all connecting wires and soldered joints and check the continuity of all choke and transformer windings. Check the external cable to mains or battery. Check all input and output voltages on load. If both types of P.S.U. are held, both units should be checked.

Unit maintenance record

8. On completion of maintenance the appropriate entry will be made on AF B2661 (see Table 1003).

FAULT FINDING

9. In the event of a fault occurring on the receiver, it may be localised:-

- (a) by observing the action of the controls
- (b) by making the voltage and resistance checks detailed in Table 1001
- (c) by detailed testing of components.

10. Table 1001 has been drawn up for a Mk 1 receiver. The corresponding values for the Mk 2 receiver should generally be similar. Where the values differ widely, both are noted. The readings were taken under the following conditions, using Instrument testing, AVO, universal, 46 range, Mk I or 50 range.

- (a) S-meter switch OFF
- (b) AUDIO GAIN at 10
- (c) A.V.C. OFF
- (d) C.W. oscillator OFF
- (e) Selectivity set vertical
- (f) PHASING at 5
- (g) R.F. GAIN at 10
- (h) H.T. ON
- (j) No phones in use and loudspeaker terminals linked
- (k) Coil unit for 50-100kc/s range.

11. Table 1002 gives a number of possible faults and the action required.

Note: The next page is Page 1001.

Table 1001 - Voltage and resistance test figures

Valve	Electrode	Valve base pin No.		D.C. voltage to chassis		Resistance to chassis		Remarks
		Mk 1	Mk 2	Mk 1	Mk 2	Mk 1	Mk 2	
V1	Anode Screen Cathode Grid	2 3 5 T/C	3 4 8 T/C	250 100 3.0 -	220 85 -	30kΩ 24kΩ 300Ω 750kΩ	40kΩ	1.5MΩ with A.V.C. ON
V2	Anode Screen Cathode Grid	2 3 5 T/C	3 4 8 -	250 100 1.5 -	220 85 -	30kΩ 24kΩ 300Ω - 10kΩ 150kΩ	40kΩ	Maximum with minimum R.F. gain
V3	Anode Screen Cathode Grid	2 3 5 T/C	3 4 8 T/C	250 65 3.0 -	220 85 -	30kΩ 200kΩ 5kΩ 80Ω	40kΩ	
V4	Anode Screen Cathode Grid	2 3 5 T/C	3 4 8 T/C	250 100 - -2.4	220 85 -	30kΩ 50kΩ - 20kΩ	40kΩ	
V5	Anode Screen Cathode Grid	2 3 5 T/C	3 4 8 T/C	220 100 2.6- 33 -	200 85 -	30kΩ 24kΩ 300Ω - 10kΩ 750kΩ	40kΩ	Maximum with minimum R.F. gain 1.5MΩ with A.V.C. ON
V6	Anode Screen Cathode Grid	2 3 5 T/C	3 4 8 T/C	220 100 12- 40 -	200 85 -	30kΩ 24kΩ 2.6Ω - 12kΩ 750kΩ	40kΩ	Maximum with minimum R.F. gain 1.5MΩ with A.V.C. ON
V7	Anode Screen Cathode Grid	2 3 6 T/C	6 - 3 2	75 35 1.2 -	150 -	220kΩ 20kΩ 800Ω 500kΩ	100kΩ	Mk 1 only With maximum A.F. gain
V8	Anode Screen Cathode Grid	2 3 5 T/C	3 4 8 T/C	25 12 - -		150kΩ 85kΩ - 50kΩ		With C.W. oscillator switched on
V9	Anode Screen Cathode Grid	2 3 5 4	3 4 8 5	250 250 15 -	220 220 12 -	30kΩ 30kΩ 500Ω 500kΩ	40kΩ 40kΩ 300Ω	

Table 1002 - Fault location

Symptom	Possible fault	Action
1. Set dead	(a) Fault in power supply unit or leads	1. Examine all power leads and plugs 2. (a) Test power unit fuses and indicator lamp. Check rectifier valve. Test SW1, C1, C2 and power transformer. (b) On D.C. working check battery volts. Recharge if necessary. Check fuse and test switch
Set dead, but pilot lamp lights up	(a) No H.T. on receiver	1. Test switch on receiver and examine external connecting leads from P.S.U. 2. Test P.S.U. as follows:- (a) A.C. working: test fuse F1, V1 (CV1863), C3, C4A, C4B, L1, L2 and L3. Test secondary windings of transformer (b) D.C. working: if vibrator not functioning replace with known good one. Test V1A. (CV692) by replacement with known good one. Test all associated smoothing components.
3. Set dead but H.T. and L.T. present	(a) Faults in A.F. stages (b) Faulty phones or loudspeaker	1. Check voltage on pins of V7 and V9 (see Table-1001) Test valves by replacing them with known good ones 2. Test loudspeaker and output transformer or phones. Examine jack JK1 for good contact

Table 1002 - (contd)

Symptom	Possible fault	Action
<p>4. No signals but noise present</p>	<p>(a) Fault in local oscillator</p> <p>(b) Fault in R.F. stages</p> <p>(c) Fault in I.F. or detector stages</p>	<p>1. Measure voltage at pins of V4 (see Table 1) Test V4 by replacement with known good one. If coil unit is suspected change frequency band and report as necessary.</p> <p>2. Measure voltages on pins of V1, V2 and V3 (see Table 1) replace valves with known good ones. Test receiver on another frequency band.</p> <p>3. Measure volts at pins of V5, V6 and V7. Test valves by replacement with known good ones</p>
<p>5. Low sensitivity</p>	<p>(a) Low H.T. volts</p> <p>(b) Valve faults</p> <p>(c) Fault in R.F. or I.F. stages</p> <p>(d) Faulty aerial system</p>	<p>Check supply voltage. Test P.S.U. and replace any fault components</p> <p>Replace all valves one at a time. Always replace the old valve if sensitivity does not improve</p> <p>Take action as detailed in 4 above</p> <p>Inspect and repair aerial system</p>

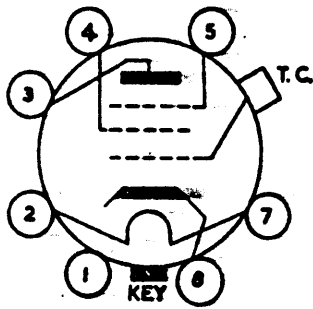

6K7 AND 6J7
CV 1942 and CV 1936

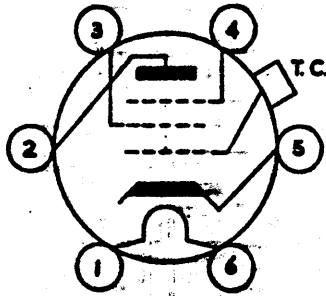

6D6 AND 6C6
CV 1900 and CV 585

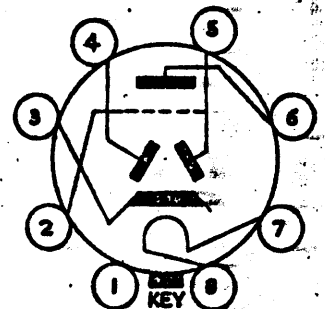

6SQ7
CV 1990

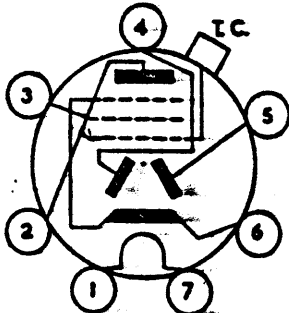

6B7
CV 1891

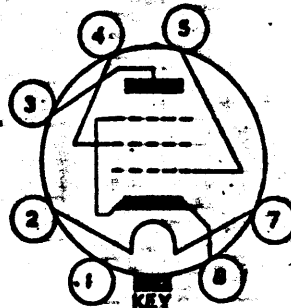

6V6 - G/GT
CV 58

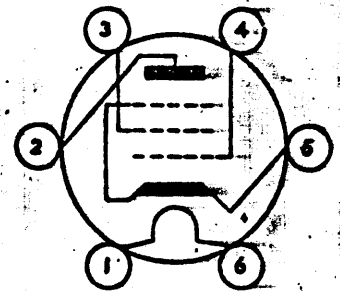

42
CV 609

E-183
1-1001

PIN NUMBERS VIEWED
FROM UNDERSIDE OF BASE

Fig 1001 -- Valve bases

57/Maint/4016

END

ELECTRICAL AND MECHANICAL
ENGINEERING REGULATIONS
(By Command of the Army Council)

RECEPTION SET R 106

TECHNICAL HANDBOOK - FIELD AND BASE REPAIRS

SUBJECT INDEX

	<u>Para</u>
INTRODUCTION	1
 MECHANICAL ADJUSTMENTS AND REPLACEMENTS	
Removal of ganged capacitor assembly	2
Dismantling the drive assembly	3 - 5
Dismantling of gang capacitor	6 - 17
 ALIGNMENT AND SPECIFICATION TESTING	
General	18 - 19
Test equipment	20
Test conditions	21 - 22
I.F. and crystal filter alignment	23 - 27
Crystal filter check	28
C.W. oscillator alignment	29
R.F. alignment	30
Coil units E - J	31 - 33
Coil units JA - JD	34 - 36
R.F. performance	37
Sensitivity	38
Second-channel selectivity	39
Signal-to-noise ratio	40
C.W. sensitivity	41
A.V.C.	42
A.F. response	43

INDEX TO FIGURES

<u>Fig No.</u>		<u>Page</u>
1	Slow-motion drive	3
2	Gang capacitor assembly	4
3	I.F. response curve	7
4	B.F.O. attenuator	11

INDEX TO TABLES

<u>Table No.</u>		<u>Page</u>
1	I.F. response data	8
2	R.F. performance data	11
3	A.F. response data	11
10Q1	Specimen AF G3504	1001
10C2	Coil winding data	1001

INTRODUCTION

1. This regulation should be used in conjunction with Tels E 162 and E 163 which contain the technical description, circuit diagram, component values and unit repair information.

MECHANICAL ADJUSTMENTS AND REPLACEMENTS

Removal of ganged capacitor assembly
(Figs 1 and 2)

2. Remove the four panel retaining screws from the front panel and the three screws from the rear of the case. Lift the cabinet clear of the chassis. Turn the tuning dial anticlockwise beyond zero so that the dial stop A is engaged and the capacitor vanes are fully meshed. Loosen the grub screw securing the dial to the drive shaft and remove the dial. Do not disturb the annular ring gear within the dial. Unsolder the leads to the capacitor sections. Remove the four bolts securing the capacitor assembly baseplate to the mounting shelf and withdraw the whole assembly from the chassis. To replace the assembly, reverse the procedure detailed above.

Dismantling the drive assembly

3. Remove the dial and ganged capacitor assembly as detailed in para 2. The correct relative positions of the two parts of the dial are shown in Fig 1. Care must be taken to ensure that, with the dial window displaying the 0 at 11 o'clock, the two retaining springs are in the position shown in Fig 1 and the dial grub screw is at 3 o'clock, when seen from the front of the dial. The two springs must not be above the opposite sides of the holes in the dial, which position will show a 0 in the dial window but with the grub screw lying almost opposite the 0. If assembled incorrectly the springs will be stretched against the sides of the holes instead of travelling clockwise across the space provided.

4. Remove the top cover of the gearcasing by removing the four screws, B. Secure the two halves of the split pinion, C, by a piece of stiff wire wrapped around the teeth. Remove the four screws, D, from the drive shaft bush, E and remove the bush. The drive shaft and worm can now be freed from the pinion and withdrawn from the gear housing bringing with it the two washers, spring and ball bearing.

5. To replace the assembly reverse the procedure detailed above. Note the word 'top' embossed on the drive shaft bush. Correct orientation of this bush is essential to obtain the correct positioning of the eccentric bearing supporting the numbered dial plate.

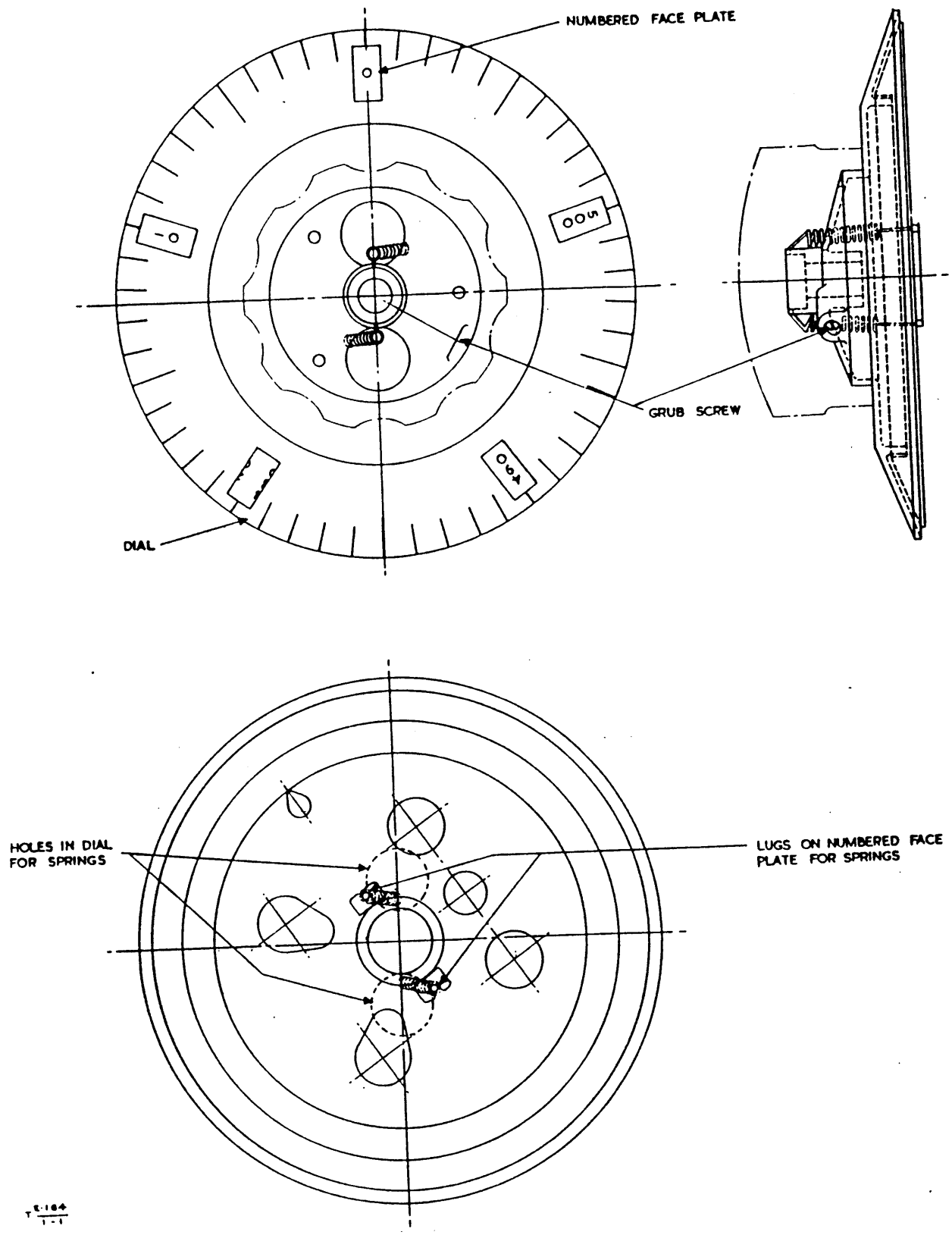

E-164
1-1

Fig 1 - Slow motion drive

Dismantling the gang capacitor (Fig 2)

- 6. The gang must not be dismantled unless absolutely necessary. Each pair of rotors and stators are carefully matched and it is important that each section is marked before dismantling to ensure reassembly in the same order.
- 7. Remove the gang assembly from the set as in para 2. Remove the gearcase top cover and the drive shaft bush, E. Secure the two halves of the split gear, C, by a piece of copper wire wrapped around the teeth. Remove the drive spindle as detailed in para 4.

TELE E 11

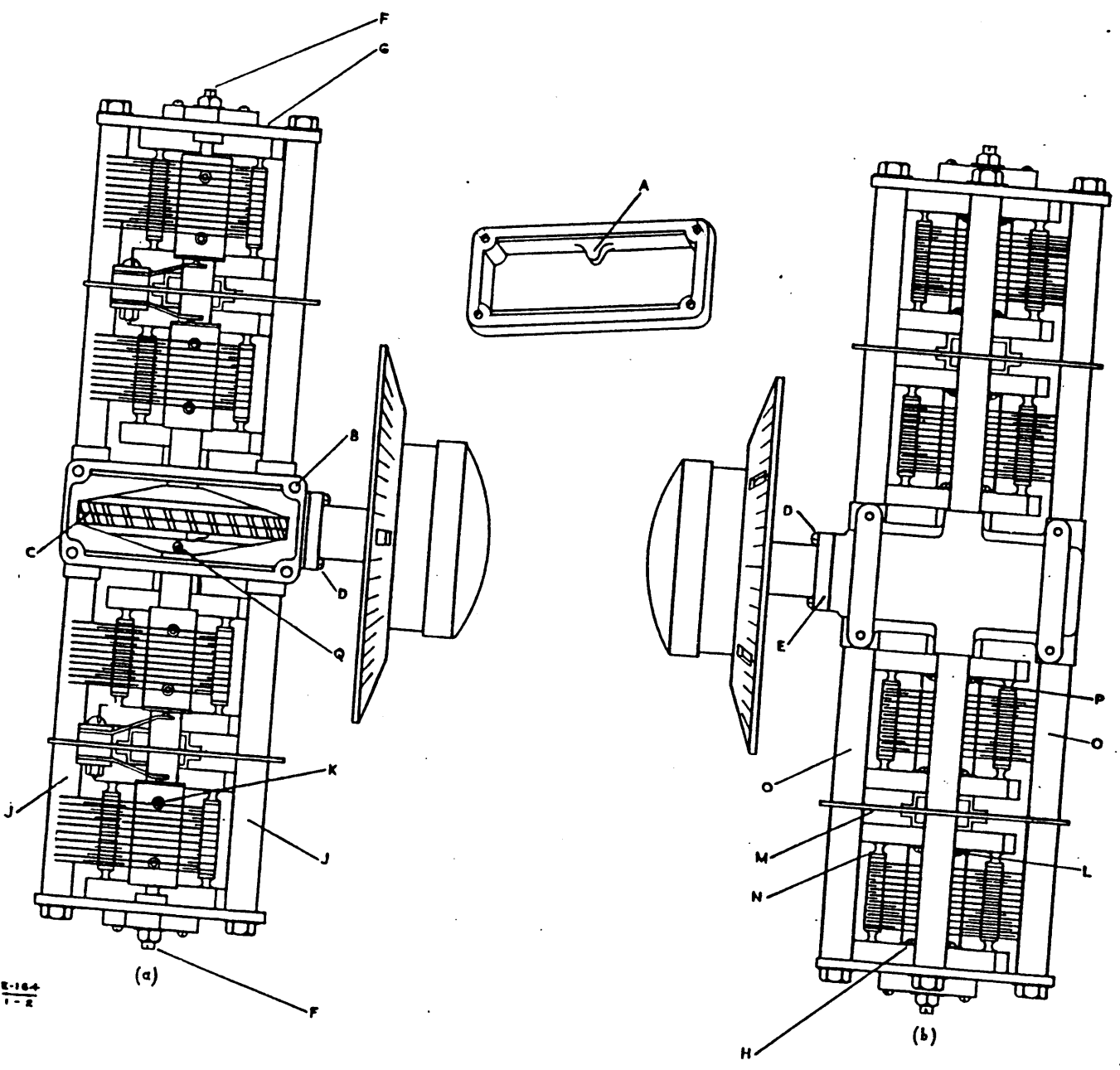

E-164 1-2

Fig 2 - Gang capacitor assembly

Issue 1, 15 Apr 54

ELECTRICAL AND MECHANICAL
ENGINEERING REGULATIONS

8. Slacken off the bearing screws, F and remove the three nuts from the end plates, G. Remove the two screws, H, securing the outer stator insulator bars to the endplates. Remove the endplates and spacers, J.
9. Loosen the Allen-screws, K, securing the outer rotors to the spindle and remove the rotors taking care not to distort the vanes. Remove the screws, L, securing the inner stator insulator bars to the screens, M, and remove the screens complete with outer stators, N and spacing pieces, O.
10. Remove the screws, P, securing the inner stator insulator bars to the gearbox and remove the inner stator assemblies.
11. Loosen the Allen-screws securing the inner rotors to the spindle and remove the rotor taking care not to distort the vanes.
12. Loosen the setscrews, Q, securing the large drive gear to the spindle and remove the spindle. Note that the gear is a die-casting and should be handled carefully and not allowed to drop out of the gearbox.
13. Reassembly is carried out by reversing the procedure detailed above but without tightening the rotor setscrews until the endplate bearing screws have been adjusted as follows.
14. After assembling the endplates and tightening the securing nuts, locate the spindle centrally between the bearings by slackening off one bearing screw and tightening the other until all end play is just taken up leaving the spindle to rotate quite freely between centres. The bearing screws must not be over-tightened.
15. The rotors can now be lined up with their respective stators ensuring that the vanes are centrally located and the setscrews tightened. Check that the position of any stator relative to the remainder is the same by lining up at the maximum capacity with the front edges of the vanes in line.
16. Replace the drive spindle with thrust spring, washers, bearing and cover, ensuring that the latter is the correct way round. Replace the large gearbox cover temporarily.
17. Position the rotors so that the 'toes' of the rotors are about $3/32$ inch below the 'toes' of the stators (ie just over the maximum capacity position). Rotate the drive spindle clockwise until the dial stop is engaged; remove the gearbox lid and tighten the setscrews in the large gear wheel. Do not overtighten the screws or damage to the spindle will result.

ALIGNMENT AND SPECIFICATION TESTINGGeneral

18. Models having air-spaced I.F. trimmers generally require very little adjustment as a result of day to day use and must not be disturbed if the I.F. amplifier has not been repaired. The alignment of sets having compression type trimmers must be checked each time the receiver undergoes repair. In the former case, it is necessary only to check the alignment to the crystal frequency (see para 24).
19. All adjustments and tests on this receiver must be carried out in a screened cage.

Test equipment

20. The following test equipment is required for alignment and specification testing:-

- (a) A frequency meter covering 125kc/s to 30Mc/s.
(eg Frequency meter, SCR 211)
- (b) An audio-frequency oscillator
(eg Oscillator, beat frequency, No.5, 7 or 8)
- (c) An output power meter for measuring powers up to 5,000mW, at 7,000 ohms
(eg Wattmeter, absorption, A.F., No. 1 or Meters, output power, No. 3)
- (d) A 1,000 ohms per volt multimeter
(eg Instruments, testing, avometer, universal, 50 range)
- (e) Signal generators covering the frequency range 85kc/s to 30Mc/s.
(eg Signal generator, No. 12 (or Signal generator, No. 1)
and Signal generator, No. 15 (or Signal generator, No. 2)).
- (f) A 1 : 1 ratio isolating transformer
(eg WY 0089)
- (g) Loudspeaker or headphones to match 7,000 ohms.

Test conditions

21. Unless otherwise stated, the output meter set to 7,000 Ω impedance will be connected across the secondary of the isolating transformer, the primary of the transformer being connected to the loudspeaker terminals. For all R.F. tests and adjustments the signal generator will be modulated to a depth of 30% at 400 c/s for I.F. tests it will be modulated 30% at 140 c/s and for crystal tests it will be modulated 30% at 90 c/s.

22. The H.T. voltage must be 250V \pm 10V, and the L.T. voltage 6.3V. The R.F. gain-control must be set at position 10 and the S-meter must be switched off.

I.F. and crystal filter alignment

23. Set the receiver controls as follows. A.F. gain to position 10, C.W. oscillator off, A.V.C. off, tuning dial to 0, selectivity control to maximum signal ie approximately vertical and phasing off. Connect the loudspeaker (or headphones) across the output meter and the signal generator, set up as in para 21, direct to the grid of V3. Short-circuit V4 grid to chassis. Insert coil unit E. Using the frequency meter, tune the signal generator to exactly 456kc/s and with an input of 1mV, which should be reduced as necessary during alignment to avoid overloading, line up all I.F. transformers for maximum output.

24. Tune the signal generator to 2Mc/s, switch off the modulation, and switch on the C.W. oscillator. Set the phasing control to the mid-position and turn the selectivity control fully clockwise. Remove the short-circuit from the grid of V4. Tune the receiver for peak output, and set the C.W. oscillator control for approximately a 1kc/s beat note. Then tune the receiver through zero beat to a 1kc/s note on the other side, increasing the signal generator output as necessary to keep the volume constant. The phasing control must now be set for minimum output and this setting noted. Retune to the crystal peak frequency, switch off the C.W. oscillator and switch on the signal generator modulation. Retune all I.F. transformers for maximum output. The I.F. circuits are now aligned to the crystal frequency; the response must be checked as follows and must agree with Table 1.

25. With connections as in para 23 but with the loudspeaker disconnected and the lead to V3 grid removed, set the signal generator to 456kc/s on the main dial. Tune the incremental dial for maximum output, varying the selectivity control as necessary. This setting should not then be disturbed during this test. Set the signal generator output to 100µV, and the A.F. gain for 200mW on the output meter. Increase the input to 200µV. Using the signal generator main dial, detune on either side of the peak until the output meter again shows 200mW. The frequency difference of the two settings is the bandwidth at 6db down. Repeat for 20, 40 and 60db down and for 6db down with the selectivity control fully clockwise, detuning the signal generator about 20kc/s before increasing the input and decreasing the input before tuning through the peak, to avoid damage to the output meter (Table 1, items a to e)

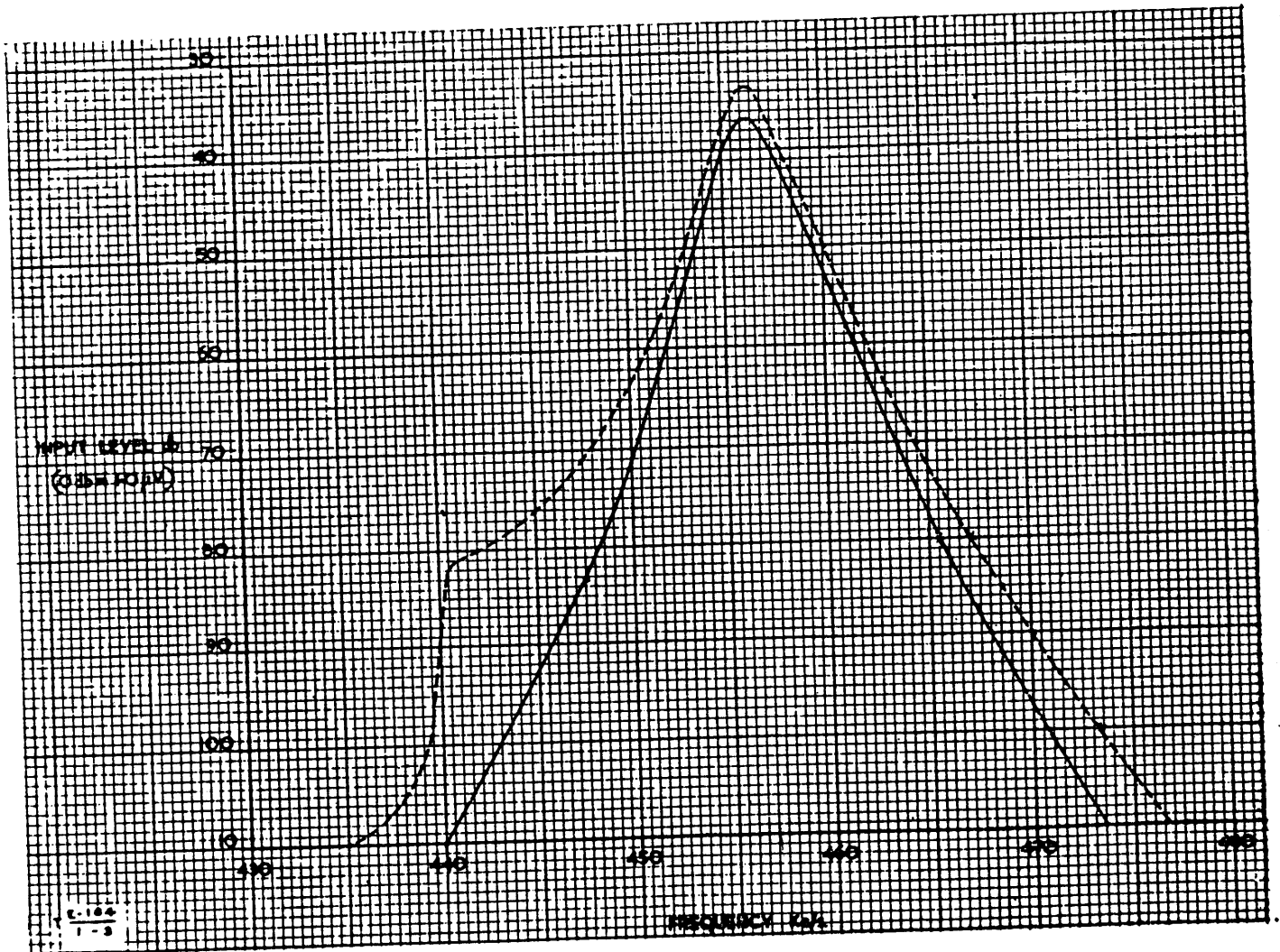

Fig 3 - I.F. Response curve

26. The I.F. response must be symmetrical and free from double humping. If either of these faults appears to be present, plot the entire I.F. curve. A specimen curve is reproduced at Fig 3. The dotted portion shows incipient double humping. This can be cured by careful adjustment of C48 but as this trimmer seriously affects the gain of the amplifier, a compromise must be made between gain and ideal curve shape. Asymmetry can be cured by very slight adjustments to the other I.F. transformers; increasing the primary capacitance and decreasing the secondary - or vice versa - will usually clear the fault.

27. No hard and fast figure of I.F. gain can be given for the R106, as it is dependent on the value of R9, which can be anything from 1kΩ to 5kΩ and is chosen in manufacture to give a satisfactory overall performance. If, however, an output of 1W cannot be obtained with conditions as in para 25 for an input of 100μV, with R.F. and A.F. gain-controls at maximum, the I.F. or A.F. stages require attention.

Crystal filter check

28. With the connections as in para 25 but with the phasing control at the setting noted in para 24 set the main dial of the signal generator to 456kc/s. Adjust the incremental dial to the crystal peak frequency, as shown by maximum output on the output meter. With a 400μV input, adjust the A.F. gain-control for 50mW output. Increase the input to 800μV and detune the incremental dial for 50mW on the output meter. Switch off the modulation, remove the signal generator output lead from V3 and with the frequency meter loosely coupled to it, determine the signal generator frequency, increasing the output if necessary to obtain a clear beat note. Repeat on the other side of the response curve. The difference in frequency is the bandwidth at 6db down and should agree with Table 1 (item f).

Item	Attenuation	Bandwidth	Control settings and test conditions
a	6db	Not less than 3.5kc/s	Phasing control at 0, selectivity control set for maximum signal, signal generator modulated 30% at 140 c/s
b	20db	Not more than 8.5kc/s	
c	40db	Not more than 16kc/s	
d	60db	Not more than 25kc	
e	6db	Not more than 2.5kc/s	Selectivity control fully clockwise. Phasing at 0
f	6db	Not more than 0.4kc/s	Phasing at noted setting, any position of selectivity control

Table 1 - I.F. response data

C.W. oscillator alignment

29. With connections as in para 23 tune the signal generator for peak output. Switch off the modulation and switch on the C.W. oscillator. Zero beat should be found with this control at position 9. Trimmers C59 and C60 must be adjusted to give this result.

R.F. alignment

30. Nine R.F. coil units are provided with the receiver. They are aligned in manufacture as a complete equipment and should not normally require any adjustment in service. If however a coil unit is replaced the alignment should be checked in the following manner.

Coil units E to J

31. With the C.W. oscillator in position 9, R.F. gain at 9, A.F. gain at 10, A.V.C. off, phasing at 0, selectivity control vertical and the loudspeaker connected across the output meter, turn the tuning dial to 490 and loosely couple the frequency meter set to the frequency indicated on the coil unit calibration chart, to the aerial terminal of the receiver. Adjust C56 for zero beat. Rotate the tuning dial to 50 and reset the frequency meter. Adjust C57 (padding condenser) for zero beat. If this adjustment proves insufficient, the short-circuited turn, coupled to L15, must be adjusted. Turning this in the general direction of the winding increases the inductance and against the general direction of the winding decreases the inductance. This is a critical adjustment and must be carefully carried out.

32. When the local oscillator has been adjusted at the L.F. end of the band, the H.F. end test must be repeated and then the L.F. end tested again, until the calibration over the whole of the band is within $\pm 3\%$ of the indicated frequency.

Note: As frequency meter SCR 211 does not cover 90kc/s it will be necessary with coil unit J to check the second harmonic of the signal generator, tuned to 90kc/s, against the SCR 211 tuned to 180kc/s.

33. The R.F. stages can now be aligned to the local oscillator. Switch off the C.W. oscillator and replace the frequency meter by the signal generator. Switch on the modulation and set the output to 10 μ V at approximately the frequency indicated by 490 on the receiver tuning dial. Set the tuning dial at 490 and tune the signal generator for maximum output on the output meter, reducing A.F. gain as necessary. C36, C40 and C44 must now be adjusted for maximum output. No L.F. adjustments are provided for these coil units.

Coil units JA to JD

34. The calibration procedure at the H.F. end of the band is identical with that for coil units E to J (para 31), except that for coil unit JA two settings of C56 are possible. The lower capacitance value is correct ie local oscillator frequency higher than signal frequency.

35. Calibration at the L.F. end is accomplished by moving either a small turn inside the coil, or, in the case of coil unit JD screwing a brass slug into or out of the coil. The coil inductance is maximum when the counter-turn runs in the same direction as the main winding, or the brass slug is screwed out of the coil. It is at a minimum when the counter-turn moves in the opposite direction to the main winding, or when the brass slug is at the centre of the coil. Neither of these are critical adjustments. As in the case of coil units E to J, calibration adjustments should be repeated at each end of the band until the calibration is within $\pm 3\%$ of the indicated frequency.

36. R.F. stage alignment is similar to that for coil units E to J, the trimmers concerned being C36, C40 and C44 and the L.F. end adjustment is made by a counter-turn as in para 35. Adjustments should be repeated at both ends of the band until the R.F. stages are in track with the oscillator.

R.F. performance.

37. For all these tests the controls must be set as follows except where otherwise stated: R.F. gain at 10, A.F. gain set for 1W output, S-meter, phasing, and A.V.C. off. The selectivity control must be set for maximum output and the loudspeaker disconnected. The signal generator must be connected to the aerial terminal via a 500Ω resistor and the earth terminal connected to chassis. All valve shields must be in place, the lid closed and the bottom in place.

Sensitivity

38. The sensitivity must agree with column 3 of Table 2.

Second-channel selectivity

39. At each of the frequencies in column 2 of Table 2, set the A.F. gain to give an output of 1W with an input of 10 μ V from the signal generator. The receiver must be tuned exactly to resonance. The signal generator is now tuned approximately to the second-channel frequency in column 4 and the signal generator output increased by the amount shown in column 5. The signal generator is now tuned for maximum A.F. output at the second-channel frequency; this output should not exceed 1W. Check that the signal generator output has not varied with the change of frequency and if necessary reset at the new frequency.

Signal-to-noise ratio

40. With conditions as in para 37 and with an input of 10 μ V at each frequency in column 2 of Table 2, switch off the signal generator modulation. The resultant A.F. output due to noise must not exceed 10mW.

C.W. sensitivity

41. With conditions as in para 37 tune the set to each of the frequencies in column 2 of Table 2. Connect the loudspeaker across the output meter, switch off the signal generator modulation and switch on the C.W. oscillator. Set C.W. oscillator for a beat note of approximately 1kc/s, reduce the signal generator input to 2 μ V and remove the loudspeaker. The output must not be less than 1W.

A.V.C.

42. With conditions as in para 37 but with A.V.C. switched on, apply 10 μ V from the signal generator to the receiver. Set the A.F. gain control for 10mW output. Increase the input to 100,000 μ V. The output must not exceed 1W.

A.F. response

43. In order to obtain the low voltages necessary for this test a simple 10 to 1 attenuator (see Fig 4) must be manufactured locally. Connect the B.F.O. via the attenuator to the junction of R13 and C12 and to chassis. With the A.F. gain control set for 1W output, the A.F. response must be as shown in Table 3.

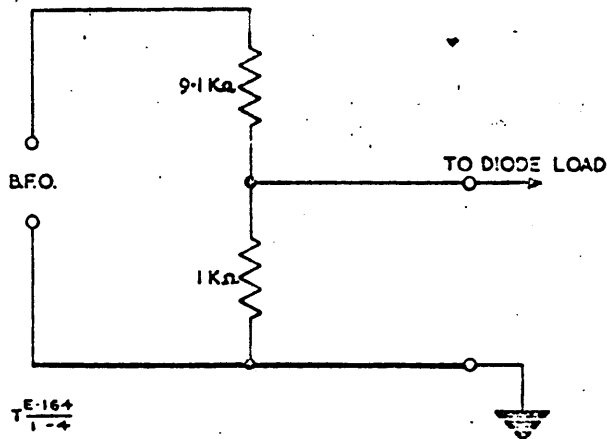

Fig 4 - B.F.O. attenuator

Coil unit (1)	Frequency (2)	Input (max) (3)	Second-channel frequency (4)	Second-channel ratio (min) (5)
JA	24Mc/s	4μV	24.912Mc/s	25db
JB	14Mc/s	4μV	14.912Mc/s	50db
JC	7Mc/s	4μV	7.912Mc/s	70db
JD	3.8Mc/s	4μV	4.712Mc/s	80db
E	1.95Mc/s	4μV	2.862Mc/s	80db
F	0.9Mc/s	4μV	1.812Mc/s	80db
G	0.4Mc/s	3μV	1.312Mc/s	80db
H	0.19Mc/s	3μV	1.102Mc/s	80db
J	0.09Mc/s	3μV	1.002Mc/s	80db

Table 2 - R.F. performance data

Frequency	Input to diode load (max)	Attenuation relative to 1kc/s
0.1kc/s	1V	+10.5db
0.2kc/s	0.45V	+3.5db
0.5kc/s	0.35V	+0.2db
1kc/s	0.3V	0db
2kc/s	0.35V	+0.2db
4kc/s	0.45V	+3.5db
6kc/s	0.5V	+4.0db
8kc/s	0.6V	+6.0db

Table 3 - A.F. response data

Note: The next page is Page 1001

R E S T R I C T E D

ELECTRICAL AND MECHANICAL
ENGINEERING REGULATIONS

TELECOMMUNICATIONS
E 164

Table 1001 - Specimen AF G3504

Tests recorded correspond with those detailed
in Tels E 164 against the para numbers shown.

Para	Spec figure	Fig obtained	Pass
25	As Table 1 (a - e)		
28	As Table 1 (f)		
29	Position 9		
38	As column 3, Table 2		
39	As column 5, Table 2		
40	Not more than 10mW		
41	Not less than 1W		
42	Not more than 1W		
43	As column 2, Table 3		
Result of test Signature			

Table 1002 - Coil winding data

Coil and winding	Wire gauge (B and S)	No. of turns	Spacing	Inductance	D.C. resistance
Range 50-100kc/s, coil unit J					
Aerial					
Pri	32 ESS	125	1/4 inch wave	200μH	3.3Ω
Sec	5/41 Litz	1350	3/8 inch wave	21.7mH	78.6Ω
1st R.F.					
Pri	32 ESS	75	1/4 inch wave	81μH	2Ω
Sec	5/41 Litz	1350	3/8 inch wave	26.8mH	78.6Ω
2nd R.F.					
Pri	32 DS	6.5	60 t.p.i.	1.09μH	0.2Ω
Sec	5/41 Litz	1395	3/8 inch wave	24.5mH	78.6Ω
L.O.					
Pins 2-4	32 ESS	301	7/32 inch wave	1.52μH	10Ω
Pins 2-5	tap	267		726μH	1Ω

Position of tap 44 turns from start of winding

E 164 - HRO COIL DATA
ex Valley.

Table 1002 - Coil winding data (contd)

Coil and winding	Wire gauge (B and S)	No. of turns	Spacing	Inductance	D.C. resistance
Range 100-200kc/s, coil unit H					
Aerial	32 ESS	156	1/4 inch wave	511 μ H	10 Ω
Pri	32 ESS	720	5/16 inch wave	6.83mH	22 Ω
Sec					
1st R.F.	38 ESS	2770	7/16 inch wave	15.4mH	33 Ω
Pri	38 ESS	730	3/8 inch wave	8.32mH	25 Ω
Sec					
2nd R.F.	32 DS	10	60 t.p.i.	22.2 μ H	53 Ω
Pri	32 ESS	724	3/8 inch wave	7.73mH	23 Ω
Sec					
L.O.	32 ESS	270	1/4 inch wave	1mH	19 Ω
Pins 2-4	(tap)	227		0.787mH	20 Ω
Pins 2-5					
Position of tap 43 turns from start of winding					
Range 180-430kc/s, coil unit G					
Aerial	32 ESS	87	3/16 inch wave	167 μ H	2.6 Ω
Pri	32 ESS	402	3/16 inch wave	3mH	14.5 Ω
Sec					
1st R.F.	38 ESS	2000	3/8 inch wave	42.7mH	210 Ω
Pri	32 ESS	402	1/4 inch wave	3.1mH	14.5 Ω
Sec					
2nd R.F.	32 EN	8	60 t.p.i.	1.63 μ H	0.2 Ω
Pri	32 ESS	402	1/4 inch wave	3.05mH	14.5 Ω
Sec					
L.O. Pins	32 ESS	202	1/4 inch wave	605 μ H	6.5 Ω
Pins 2-4	(tap)	134		305 μ H	4.5 Ω
Pins 2-5					
Position of tap 68 turns from start of winding					

Table 1002 - Coil winding data (contd)

Coil and winding	Wire gauge (B and S)	No. of turns	Spacing	Inductance	D.C. resistance
Range 480-960kc/s, coil unit F					
Aerial Pri Sec	30 DS 10/41 Litz	37 143	3/16 inch wave 3/16 inch wave	25.5μH 377.0μH	0.7Ω 3.8Ω
1st R.F. Pri Sec Cap	32 ESS 10/41 Litz 26 DS	676 143 1	1/4 inch wave 3/16 inch wave	48.5mH 387μH	4.5Ω 3.8Ω
2nd R.F. Pri Sec	30 DS 10/41 Litz	6 143	60 t.p.i. 3/16 inch wave	1.36μH 379μH	0.1Ω 3.8Ω
L.O. Pins Pins 2-4 Pins 2-5	10/41 Litz	95 29	3/16 inch wave	110μH 79.5μH	2.4Ω 0.8Ω
Position of tap 66 turns from start of winding					
Range 900-2050kc/s, coil unit E					
Aerial Pri Sec	30 DS 10/41 Litz	22 81	3/8 inch wave 3/8 inch wave	11.6μH 120μH	0.4Ω 2.2Ω
1st R.F. Pri Sec Cap	36 ESS 10/41 Litz 26 DS	465 81 1	1/4 inch wave 3/16 inch wave	2.12mH 120μH	27Ω 2.1Ω
2nd R.F. Pri Sec	30 DS 10/41 Litz	16 81	60 t.p.i. 5/32 inch wave	4.9μH 120μH	0.3Ω 2.1Ω
L.O. Pins Pins 2-4 Pins 2-5	10/41 Litz	62 13	3/16 inch wave	79.2μH 48μH	1.7Ω 0.4Ω
Position of tap 49 turns from start of winding					

Table 1002 - Coil winding data (contd)

Coil and winding	Wire gauge (B and S)	No. of turns	Spacing	Inductance	D.C. resistance
Range 1.7-4Mc/s, coil unit JD					
Aerial					
Pri	32 DS	10	60 t.p.i.	4.98μH	0.6Ω
Sec	28 EN	40	60 t.p.i.	35.8μH	0.8Ω
1st R.F.					
Pri	36 ESS	257	3/16 inch wave	61.5μH	14.0Ω
Sec	28 EN	40	60 t.p.i.	35.9μH	0.8Ω
2nd R.F.					
Pri	36 ESS	257	3/16 inch wave	615.3μH	14Ω
Sec	28 EN	40	60 t.p.i.	35.7μH	0.18Ω
L.O. Pins					
Pins 2-4 (slug out)	28 EN	37	60 t.p.i.	30.9μH	0.8Ω
Pins 2-5 (slug in)		30		37.6μH	
				19.1μH	0.6Ω
Position of tap 6.5/6 turns from start of winding					
Range 3.5 -7.3Mc/s, coil unit JC					
Aerial					
Pri	32 DS	5	Close wound	1.7μH	0.4Ω
Sec	24 EN	21.1/2	24 t.p.i.	8.97μH	0.2Ω
1st R.F.					
Pri	36 ESS	125	1/4 inch wave	156μH	6.4Ω
Sec	24 EN	21.7/8	24 t.p.i.	9.46μH	0.2Ω
2nd R.F.					
Pri	36 ESS	125	1/4 inch wave	156μH	6.4Ω
Sec	24 EN	21.7/8	24 t.p.i.	10.2μH	0.2Ω
L.O. Pins					
Pins 2-4	24 EN	19.1/2	24 t.p.i.	7.69μH	0.2Ω
Pins 2-5		15.3/4		5.67μH	0.16Ω
Position of tap 3.3/4 turns from start of winding					

Table 1002 - Coil winding data (contd)

Coil and winding	Wire gauge (B and S)	No. of turns	Spacing	Inductance	D.C. resistance
Range 7-14.4Mc/s, coil unit JB					
Aerial					
Pri	32 DS	4	Close wound	1.22μH	0.3Ω
Sec	24 EN	7	24 t.p.i.	1.38μH	0.1Ω
Cap	26 DS	1/2			
1st R.F.					
Pri	36 ESS	65	1/4 inch wave	39.1μH	3.3Ω
Sec	24 EN	8.11/16	24 t.p.i.	2.3μH	0.1Ω
Cap	32 DS	1/2			
2nd R.F.					
Pri	32 DS	2.3/4	24 t.p.i.	0.653μH	0.1Ω
Sec	24 EN	7.1/2	24 t.p.i.	2.163μH	0.1Ω
L.O. Pins					
Pins 2-4	22 EN	10	24 t.p.i.	2.0μH	-
Pins 2-5		7.1/6		0.537μH	-
Position of tap 2.5/6 turns from start of winding					
Range 14-30Mc/s, coil unit JA					
Aerial					
Pri	32 DS	5	Close wound	0.523μH	0.1Ω
Sec	22 EN	5	24 t.p.i.	0.661μH	-
1st R.F.					
Pri	36 DS	9.1/2	24 t.p.i.	1.35μH	0.7Ω
Sec	22 EN	10	24 t.p.i.	0.314μH	-
Ter	40 EN	50	230 t.p.i.	49.3μH	9.7Ω
2nd R.F.					
Pri	36 DS	9.1/2	24 t.p.i.	1.33μH	0.7Ω
Sec	22 EN	10	24 t.p.i.	0.283μH	-
Ter	40 EN	50	230 t.p.i.	48.6μH	9.7Ω
L.O. Pins					
Pins 2-4	22 EN	6.1/3	24 t.p.i.	0.780μH	-
Pins 2-5	(tap 1)	4.1/3			-
	(tap 2)	1.7/12			-
Position of taps. 2 turns and 4.3/4 turns from start of winding					

Table 1002 - Coil winding data (contd)

Coil and winding	Wire gauge (B and S)	No. of turns	Spacing	Inductance	D.C. resistance
1st and 2nd I.F. transformer (L7/8 and L9)					
Pri Sec output tap	10/41 Litz	235	3/16 inch wave	1.5mH	7.3Ω
	10/41 Litz	235	3/16 inch wave	1.5mH	7.3Ω
	10/41 Litz	297	3/16 inch wave	1.93mH	10Ω
	10/41 Litz	233	3/16 inch wave	1.48mH	7.2Ω
3rd I.F. transformer (L10/11)					
Pri Sec	10/41 Litz	260	3/16 inch wave	1.57mH	7.6Ω
	10/41 Litz	260	3/16 inch wave	1.57mH	7.6Ω
4th I.F. transformer (L12/13)					
Pri Sec	10/41 Litz	260	3/16 inch wave	1.57mH	7.6Ω
	10/41 Litz	260	3/16 inch wave	1.57mH	7.6Ω
C.W. oscillator transformer					
Overall Tap	32 ESS	223 152	1/4 inch wave	860μH 470μH	7.1Ω 4.9Ω

N.B. The coils should be measured to the following tolerances.

Coils E, F and G should be wound without the iron dust core; this should be inserted when measuring the coil inductance and its position varied to give the inductance figure stated to within 2%. Cores should be locked in position with YC 00600 wax, sealing, iron dust core.

Coil JA. The local oscillator coil should be wound to the limits shown.

All other coils should be wound to within 3% of the stated value. Their actual value will be dependent upon the position of the counter turn (paras 35-36) or the short-circuited turn (para 31).

57/Maint/4016

END

JANUARY, 1945

93AIT
PL/ESNA-6008

RESTRICTED

The information given in this document is not to be communicated, either directly or indirectly to the Press or to any person not authorized to receive it.

COVERING
MAINTENANCE
SCHEDULES:

N.A. 1370

N.A. 1373

N.A. 1802

N.A. 1805

PARTS LISTS

RECEPTION SETS R. 106, MKs. 1 & 2

(NATIONAL CO. MODELS HRO, HRO-M, HRO-MX AND HRO-5T)

BRITISH ARMY STAFF
NORTH AMERICA

READ THIS

PREFACE

1. The Catalogue Numbers and Designations in this Parts List must always be used when demanding maintenance spares.
Any Lists issued prior to the date of this publication, are therefore superseded by this Parts List, in respect of Catalogue Numbers and Designations.
2. Although U.S. Signal Corps stock numbers and designations are used, slight alterations have been made to conform with accepted British Cataloguing and Designating standards, i.e.
 - (a) U.S. Signal Corps stock numbers bear the prefix letters of the relevant V.A.O.S. Section.

(b)

U.S. Signal Corps main nouns (and type numbers, where applicable) have been used in the designations throughout this list.

In many instances, however, there is a great difference between American and British terminology when referring to Signal Components.

Owing to this variance in nomenclature the corresponding British name has been included in brackets in the designation to avoid confusion and to assist Units in utilizing this List in conjunction with any other British or U.S. Army documents already in existence.

----- AND THESE

NOTES

1. Items in this Parts List marked with an asterisk (*) are not approved maintenance items but may be issued until stocks are exhausted.

ITEMS NOT SO MARKED ARE APPROVED MAINTENANCE ITEMS FOR THE EQUIPMENT CONCERNED AND WILL BE DEMANDED IN THE USUAL MANNER.

SEE ALSO PREFACE - Para. 1.
2. This Parts List has been prepared by British Army Staff, North America, in close liaison with the U.S. Signal Corps and the manufacturing Plants concerned. Any queries on this list should be addressed to:-

BRITISH ARMY STAFF
Q.M.G. BRANCH
1901 K STREET, N.W.
WASHINGTON, D.C., U.S.A.

quoting Parts List PL/ESNA-6008.
3. THE 'ISSUES-IN-LIEU' QUOTED IN THIS PARTS LIST APPLY ONLY TO THE RECEPTION SETS R-106 MK. 1 & 2 AND IT MUST NOT BE ASSUMED THAT THEY MAY APPLY TO OTHER EQUIPMENTS.

PARTS LIST PL/ESNA-6008

for

RECEPTION SETS R. 106, MK. 1 & MK. 2

INCLUDES THE FOLLOWING COMPONENT LISTS:

CL/ESNA-33
CL/ESNA-34
CL/ESNA-35

Reception Sets, R.106, Mk. 1 & 2.
Pack, Vibrator (Vibra-pack) 686S, Complete.
Power Supply Unit, Type 697, Complete.

INDEX TO MANUFACTURERS' CODE

A-1
A-17
C-6
C-15
H-20
N-1
S-8

Aerovox Corp.
Arrow, Hart & Hegeman Co.
Cinch Mfg. Corp.
Cornell Dubilier Electric Co.
Holtzer-Cabot Electric Co.
National Co.
Sprague Products Co.

RECEPTION SETS R106 MK. 1 (ZA/2C452) (2)
 (MODELS HRO, HRO-M & HRO-MX)
 RECEPTION SETS R106 MK. 2 (ZA/USA/1023)
 (MODEL HRO-5T)

(1)	(2)	(3)	(4)	(5)	(6)	(7)	(8)	(9)	(10)
ITEM No.	VAOS Sec. Code	MFRS. CODE	PIECE PT. OR Dwg. No.	CATALOGUE No.	DESIGNATION	SCH. OR ILL.No.	Mk.1	Mk.2	ISSUE IN LIEU
1.	Z1	N-1	BM-38	ZA/3H3986	PACK, vibrator (VIBRA-PACK) 686S (For spares see CL-34)		1	1	ZAA0318
2.	Z1	N-1	BM-75	ZA/3H4496-1	POWER SUPPLY UNIT, type 697 (For spares see CL-35)		1	1	
3.	Z1	N-1		ZA/2C4529-22	RECEPTION SET R106, Mk. 1 (Receivers HRO, HRO-M & HRO-MX)		1		ZA5751 w/o valves
4.	Z1	N-1		ZA/USA/2023	RECEPTION SET R106, Mk. 2 (Receivers HRO-5T)			1	
5.	Z1			ZA/JAN/6B7	TUBE (VALVES), type 6B7 (1 in use; 1 spare)		2		ZA5627
6.	Z1			ZA/JAN/6C6	TUBE (VALVES), type 6C6 (3 in use; 3 spare)		6		ZA5625
7.	Z1			ZA/JAN/6D6	TUBE (VALVES), type 6D6 (4 in use; 4 spare)		8		ZA5626
8.	Z1			ZA/JAN/6J7	TUBE (VALVES), type 6J7 (VT-91) (3 in use; 3 spare)			6	ZA12629
9.	Z1			ZA/JAN/6K7	TUBE (VALVES), type 6K7 (VT-86) (4 in use; 4 spare)			8	ZA12630
10.	Z1			ZA/JAN/6SQ7	TUBE (VALVES), type 6SQ7 (VT-103) (1 in use; 1 spare)			2	ZAS444
11.	Z1			ZA/JAN/6V6GT/G	TUBE (VALVES), type 6V6GT/G (1 in use; 1 spare)			2	ZA17191
12.	Z1			ZA/JAN/42	TUBE (VALVES), type 42 (1 in use; 1 spare)		2		ZA7125

(1)	(2)	(3)	(4)	(5)	(6)	(7)	(8)	(9)	(10)
ITEM No.	VAOS SEC.	MFRS. CODE	PIECE PT. OR DWG. No.	CATALOGUE No.	DESIGNATION	SCH. OR ILL.No.	Mk.1	Mk.2	ISSUE IN LIEU
13.	Z1	N-1	F350 pt. 1	ZA/3F891-20	RECEPTION SET R106, Mk. 1 & 2		1	1	ZN3043
14.	Z1	N-1	SA-21	ZA/3Z774-2	AMMETER DC, 0-1 mA., flush mtg., 2-1/2-in. molded phenolic case (Replaces ZN3041, WB2020, ZN3043)		1	1	ZN3023
15.	Z1	N-1	C-627	ZA/3E4013-3	BINDING POST ASS'Y (BLOCKS, terminal), 2 way, 2-1/8-in. lg. x 3/4-in. w. x 1-1/4-in. h. ... CABLE ASS'Y (CONNECTORS), 4 pt., 5-ft. with plug	W1	1	1	WB1535 & ZA3806 together
16.	Z1	C-6 } N-1 }	6020 } E726 }	ZA/2Z1607-19	CAP, valve, shield, 25/32-in. I.D. x 1-in. h.	6K7 } 6J7 }		7	
17.	Z1	N-1	SA-17 pt. 2	ZA/3D9002-12	CAPACITOR, mica, 2 mmf. ±50%, 400-v.D.C. wkg., No. 1, U.S. type	C-33	1	1	
18.	Z1	N-1	D825D pt.403	ZA/3D9010-26.2	CAPACITOR, ceramic, 10 mmf. ±10%, 500-v.D.C. wkg., No. 4, U.S. type	C-44	1	1	
19.	Z1	N-1	D825C pt.304	ZA/3D9100-57	CAPACITOR, ceramic, 100 mmf. ±5%, 500-v.D.C. wkg. No. 1, U.S. type		5	5	ZA1439
20.	Z1	N-1	D825C pt.315	ZA/3D9250-49.1	(Sch. ref: C12,C30,C31,C32,C42) CAPACITOR, ceramic, 250 mmf. ±10%, 500-v.D.C. wkg., No. 1, U.S. type	C-13	1	1	ZA1467
21.	Z1	N-1	E603 pt. 3	ZA/3D9500-100.1	CAPACITOR, ceramic, 500 mmf. ±10%, 1000-v.D.C. wkg., No. 1, U.S. type	C-16	1	1	ZA1441
22.	Z1	A-1 } N-1 }	1467 } D830 pt. 2 }	ZA/3K3010211	CAPACITOR, mica, .001 mf. ±10%, 500-v.D.C. wkg., No. 3, U.S. type	C-29	1	1	ZA1400

(1)	(2)	(3)	(4)	(5)	(6)	(7)	(8)	(9)	(10)
ITEM No.	VAOS Sec. Code	MFRS. CODE	PIECE PT. OR Dwg. No.	CATALOGUE No.	DESIGNATION	SCH. OR ILL. No.	Mk.1	Mk.2	ISSUE IN LIEU
23.	Z1	N-1	D827 pt. 7	ZA/3DA10-196	CAPACITOR, paper, 0.01 mf. +20%-10%, 600-v.D.C. wkg., No. 1, U.S. type (Sch. ref: C2,C7,C9,C15)	C-24 C-26 C-28	7	7	ZAL622
24.	Z1	N-1	D827 pt. 11	ZA/3DA100-129.2	CAPACITOR, paper, 0.1 mf. +20%-10%, 400-v.D.C. wkg., No. 1, U.S. type (Sch. ref: C1,C3,C6,C10,C14,C17,C20,C21,C22,C23)		10	10	ZAL367 or ZAL588
25.	Z1	N-1	D827 pt. 13	ZA/3DA100-177.1	CAPACITOR, paper, 0.1 mf. +20%-10%, 600-v.D.C. wkg., No. 1, U.S. type (Sch. ref: C4,C5,C18,C25)		4	4	ZAL367 or ZAL588
26.	Z1	N-1	D827 pt. 19	ZA/3DA250-73	CAPACITOR, paper, 0.25 mf. +20%-10%, 600-v.D.C. wkg., No. 1, U.S. type		1	1	ZAL698
27.	Z1	N-1	E340 pt. 1	ZA/3DB10-47	CAPACITOR, electrolytic, 10 mf. +150%-0%, 50-v.D.C. wkg.	C-8 C-11 C-19	2	2	ZAL625
28.	Z1	N-1	SA-14B	ZA/3D9225V-7	CAPACITOR, variable, 4 gang, 12-225 mmf.		1	1	ZAL695
29.	Z1	N-1	SA-13	ZA/3D9035V-33	CAPACITOR, variable, 5-35mmf. fitted w/bracket (Note: comprises ZAL694, Condensers variable Y3A & ZA20107)	C-27	1	1	ZAL694 together w/ ZA20107
30.	Z1	C-6 N-1	6011 F137	ZA/2C4529/2	CLIP, grid, valve, Cinch No. 6011	6K7 6J7		7	
31.	Z1	N-1	D-236	ZA/2Z2724	CLIP, grid, valve connection No. 1, U.S. type	6D6 6C6	8		ZAL2297 ZA5491/1 ZA5491/2 ZA5491/3 ZA5491/4 ZA5491/5 ZA5491/6
32.	Z1	N-1	SA-52-T	ZA/3C2625	COIL UNIT, 50 to 100 Kc/s		1	1	
33.	Z1	N-1	SA-52-O	ZA/3C2625-1	COIL UNIT, 100 to 200 Kc/s		1	1	
34.	Z1	N-1	SA-51-V	ZA/3C2625-2	COIL UNIT, 180 to 430 Kc/s		1	1	
35.	Z1	N-1	SA-51-Q	ZA/3C2625-3	COIL UNIT, 480 to 960 Kc/s		1	1	
36.	Z1	N-1	SA-51-M	ZA/3C2625-4	COIL UNIT, 900 to 2050 Kc/s		1	1	
37.	Z1	N-1	SA-58-J	ZA/3C2625-5	COIL UNIT, 1-7 to 4 Mc/s		1	1	

(1)	(2)	(3)	(4)	(5)	(6)	(7)	(8)	(9)	(10)	
ITEM No.	VAOS SEC.	MFRS. CODE	PIECE PT. OR DWG. No.	CATALOGUE No.	DESIGNATION	SCH. OR ILL. No.	Mk. 1	Mk. 2	ISSUE IN LIEU	
38.	Z1	N-1	SA-58-E	ZA/3C3625-7	COIL UNIT, 3.5 to 7.3 Mc/s COIL UNIT, 7 to 14.4 Mc/s COIL UNIT, 14 to 30 Mc/s COIL UNIT, 14 to 30 Mc/s, special (Note: not interchangeable with SA-57-0, differs in wiring and capacitors, for use on 5T set only) CRYSTAL (OSCILLATOR QUARTZ 456 Kc/s) (Now replaced by ZA/3Z1891-19, not plug in type) DIAL ASSEMBLY (HANDLE & DIAL ASS'Y), main tuning, No. 1, U.S. type FILTER, Crystal Unit I.F., with crystal 456 Kc/s (When used on Rec. Sets R106 Mk. 2, ZA/2C4529/2 must be fitted) GROMMET, rubber, 11.16-in. O.D. x 3/8-in. I.D. x 9/32-in. thk. HANDLE, panel, steel, 1/4-in. thk., tapped 3/8-in., No. 6-32 thd. JACK, telephone, single, No. 4, U.S. type KJOB (HANDLE & DIAL ASS'Y) c/w etched plate, AF gain		1	1	ZA5491/7 ZA5491/8 ZA5491/9	
39.	Z1	N-1	SA-57-T	ZA/3C3625-6				1	1	
40.	Z1	N-1	SA-57-0	ZA/3C2625-3				1		
41.	Z1	N-1	SA-2677	ZA/USA/2021					1	
42.	Z1	N-1	SA-81-B	*						
43.	Z1	N-1	SA-645	ZA/2Z3764.26					ZN3031	
44.	Z1	N-1	SA-81 } SA-2491 }	*ZA/3Z1891-19		K1	1	1	ZA1696	
45.	Z1	N-1	E923 pt. 8	ZA/6Z4856-1		T1	1	1	ZN3033	
46.	Z1	N-1	B-230	ZA/USA/2022			1			
47.	Z1	N-1	E058 pt. 1	ZA/2Z5598-8			2			
48.	Z1	N-1	SA-4	ZA/2Z5324.19			1	1	ZN3042	
							1	1	ZN3036	

(1)	(2)	(3)	(4)	(5)	(6)	(7)	(8)	(9)	(10)
ITEM No.	VAOS SEC.	MFRS. CODE	PIECE PT. OR DWG. No.	CATALOGUE No.	DESIGNATION	SCH. OR ILL. No.	Mk. 1	Mk. 1	ISSUE IN LIEU
49.	Z1	N-1	SA-6	ZA/2Z5824.21	KNOB (HANDLE & DIAL ASS'Y) c/w etched plate, c.w. oscillator	K5	1	1	ZN3037
50.	Z1	N-1	SA-7	ZA/2Z5824.22	KNOB (HANDLE & DIAL ASS'Y) c/w etched plate phasing	K3	1	1	ZN3038
51.	Z1	N-1	SA-5	ZA/2Z5824.20	KNOB (HANDLE & DIAL ASS'Y) c/w etched plate, RF gain	K4	1	1	ZN3039
52.	Z1	N-1	SA-1273	ZA/2Z5824.2	KNOB (HANDLE & DIAL ASS'Y) c/w etched plate, selectivity	K2	1	1	ZN3040
53.	Z1	N-1	F154 pt. 1	ZA/2Z5883-02	(ZN3040 is for handle only, replaced by ZA/2Z5824.2) LAMP ASSEMBLY (HOLDERS, LAMP), No. 1, U.S. type	L1	1	1	ZA16533
54.	W2	N-1	F136 pt. 6	WB/2Z5952	LAMP, LM-52, 6-8-v., 0.15 amp., MBC		1	1	WB2019
55.	Z1	C-6	1510A	*ZA/3Z3915-10A	MOUNTING STRIP (STRIPS TAG), 2 way, type 1510A		12	12	ZA14730
56.	Z2	N-1	E947 pt. 1	ZB/6L3677-32.1	NUT LOCK, brass hex., 15/32-32 thd. x .078-in. thk., 5/8-in. overall, nickel-plated		3	3	
57.	Z1	N-1	D831 pt. 2	ZA/2Z7279-22	POTENTIOMETER, 1000 ohms, 1 watt	R32	1	1	ZN3045
58.	Z1	N-1	D771 pt. 4	ZA/2Z7280-28	POTENTIOMETER, 10,000 ohms, 1.5 watt	R1	1	1	ZA8113
59.	Z1	N-1	D833 pt. 2	ZA/2Z7272-23	POTENTIOMETER, 500,000 ohms, ±20%, 2 watt		1	1	ZA6587
60.	Z1	N-1	F156 pt. 1	ZA/3Z6006D4	RESISTOR (RESISTANCES); wire wound, 64-ohms 10%, 0.2 amp.	R21	1	1	ZN3046
61.	Z1	N-1	E635 pt. 8	ZA/3Z6030-71	RESISTOR, carbon, 1/2-w., 300 ohms ±10%, Speer No. GC1-1/2	R4	3	3	ZA3417

January, 1945

(1)	(2)	(3)	(4)	(5)	(6)	(7)	(8)	(9)	(10)
ITEM No.	VAOS Sec.	MFRS. CODE	PIECE PT. OR DWG. No.	CATALOGUE No.	DESIGNATION	SCH. OR ILL.No.	Mk.1	Mk.2	ISSUE IN LIEU
62.	Z1			ZA/RC21BF331K	RESISTOR, carbon, 1/2-w., 330 ohms \pm 10%, type 21BF	R4	3	3	ZA3417
63.	Z1	N-1	E635 pt. 11	ZA/3Z6080-44	RESISTOR, carbon, 1/2-w., 800 ohms \pm 10%, Speer, No. SC1-1/2	R20	1	1	ZA3811
64.	Z1	N-1		ZA/RC21BF821K	RESISTOR, carbon, 1/2-w., 820 ohms \pm 10%, type 21BF	R20	1	1	ZA3811
65.	Z1	N-1	E635 pt. 14	ZA/3Z6200-100	RESISTOR, carbon, 1/2-w., 2000 ohms \pm 10%, Speer, No. SC1-1/2	R20	4	4	ZA6439
66.	Z1			ZA/RC21BF222K	RESISTOR, carbon, 1/2-w., 2200 ohms \pm 10%, type 21BF	R20	4	4	ZA6439
67.	Z1	N-1	E637 pt. 15	ZA/3Z6250-63	RESISTOR, carbon, 1/2-w., 2500 ohms \pm 10%, Speer, No. SC1-1/2	R11	1	1	ZA6529
68.	Z1			ZA/RC21BF222K	RESISTOR, carbon, 1/2-w., 2200 ohms \pm 10%, type 21BF	R11	1	1	ZA6529
69.	Z1	N-1	E635 pt. 17	ZA/3Z6500-150	RESISTOR, carbon, 1/2-w., 5000 ohms \pm 10%, Ohio Carbon No. PJ	R2	1	1	ZA6441
70.	Z1			ZA/RC21BF472K	RESISTOR, carbon, 1/2-w., 4700 ohms \pm 10%, type 21BF	R2	1	1	ZA6441
71.	Z1	N-1	E635 pt. 19	ZA/3Z6620-105	RESISTOR, carbon, 1/2-w., 20,000 ohms \pm 10%, Speer, No. SC1-1/2	R16	2	2	ZA6442
72.	Z1			ZA/RC21BF223K	RESISTOR, carbon, 1/2-w., 22,000 ohms \pm 10%, type 21BF	R16	2	2	ZA6442

January, 1945

(1)	(2)	(3)	(4)	(5)	(6)	(7)	(8)	(9)	(10)
ITEM No.	VAOS Sec.	MFRS. CODE	PIECE PT. OR Dwg. No.	CATALOGUE No.	DESIGNATION	SCH. OR ILL. No.	Mk.1	Mk.2	ISSUE IN LIEU
73.	Z1	N-1	E635 pt. 22	ZA/3Z6650-138	RESISTOR, carbon, 1/2-w., 50,000 ohms \pm 20%, Speer No. SCI-1/2	R13	2	2	ZA6536
74.	Z1			ZA/RC21BF473K	RESISTOR, carbon, 1/2-w., 47,000 ohms \pm 10%, type 21BF ...	R13	2	2	ZA6536
75.	Z1	N-1	E635 pt. 24	ZA/RC21BF104K	RESISTOR, carbon, 1/2-w., 100,000 ohms \pm 10%, type 21BF ..	R7	4	4	ZA6537
76.	Z1	N-1	E635 pt. 25	ZA/3Z6725-37	RESISTOR, carbon, 1/2-w., 250,000 ohms \pm 10%, Ohio Carbon No. PJ	R14 } R23 }	2	2	ZA6445
77.	Z1			ZA/RC21BF224K	RESISTOR, carbon, 1/2-w., 220,000 ohms \pm 10%, type 21BF ..	R14 } R23 }	2	2	ZA6445
78.	Z1	N-1	E635 pt. 26	ZA/3ZK6750-42	RESISTOR, carbon, 1/2-w., 500,000 ohms \pm 10%, Cent-ralab No. 710		7	7	ZA6540
79.	Z1			ZA/RC21BF474K	RESISTOR, carbon, 1/2-w., 470,000 ohms \pm 10%, type 21BF .. (Sch. ref: R3,R8,R12,R19, R26,R31,R28)		7	7	ZA6540
80.	Z1	N-1	E636-10	ZA/RC31BF473K	RESISTOR, carbon, 1 w., 50,000 ohms \pm 10%, type 31BF ...	R18		1	
81.	Z1	N-1	E637 pt. 5	ZA/RC41BF331K	RESISTOR, carbon, 2 w., 300 ohms \pm 10%, type 41BF	R25		1	
82.	Z1	N-1	E637 pt. 7	ZA/3Z6050-95	RESISTOR, carbon, 2 w., 500 ohms \pm 10%, Speer No. S1-2	R25	1		ZA3807
83.	Z1			ZA/RC41BF471K	RESISTOR, carbon, 2 w., 470 ohms \pm 10%, type 41BF	R25	1		ZA3807

(1)	(2)	(3)	(4)	(5)	(6)	(7)	(8)	(9)	(10)
ITEM No.	VAOS Sec. No.	MFRS. CODE	PIECE PT. OR DWG. No.	CATALOGUE No.	DESIGNATION	SCH. OR ILL. No.	Mk. 1	Mk. 2	ISSUE IN LIEU
84.	Z1	N-1	E637 pt. 14	ZA/RC41BF153K	RESISTOR, carbon, 2 w., 15,000 ohms \pm 10%, type 41BF	R10	1	1	ZA3808
85.	Z1	N-1	E637 pt. 16	ZA/3Z6630-56	RESISTOR, carbon, 2 w., 30,000 ohms \pm 10%, Speer No. S1-2	R15	1	1	ZA3809
86.	Z1			ZA/RC41BF333K	RESISTOR, carbon, 2 w., 33,000 ohms \pm 10%, type 41BF	R15	1	1	ZA3809
87.	Z1	N-1	E637 pt. 18	ZA/RC41BF104K	RESISTOR, carbon, 2 w., 100,000 ohms \pm 10%, type 41BF	R17	2		ZA3810
88.	Z1	N-1	T78	ZA/2ZK8309-1	SHIELD (CANS), screening valve, alum, 4-1/2-in. lg. x 1.5/8-in. dia.	6B7 } 6C6 } 6D6 }	8		1 each of the following: ZN3029, ZN3030, ZN3028
89.	Z1	N-1	E321 pt. 1	ZA/2Z8676.58	(includes body, base & cap)				ZA4273
90.	Z1	N-1	SA-72	ZA/2Z8676.59	SOCKET (HOLDERS), tube, 6 prong, No. 6, U.S. type		4		ZA3804
91.	Z1	N-1	SA-73	ZA/2Z8677.39	SOCKET (HOLDERS), tube, 6 prong, No. 7, U.S. type		4		ZA3805
92.	Z1	N-1	SA-451	ZA/2Z8678.119	SOCKET (HOLDERS), tube, 7 prong, small, No. 2, U.S. type		1		
93.	Z1	A-17	21350E	ZA/3Z9858-8.32	SOCKET (HOLDERS), tube, 8 prong, No. 28, U.S. type			9	
94.	Z1	N-1	F303 pt. 1		SWITCH, toggle, SPDT, 3 amp., 250-v., No. 1, U.S. type	X3	1	1	ZA3812
		N-1	80994	ZA/3Z9858-8.33	SWITCH, toggle, SPST, 3 amp., 250-v., No. 1, U.S. type	X1			ZA8724: note
		N-1	D851 pt. 2		SWITCH, toggle, SPST, 3 amp., 250-v., No. 2, U.S. type	X4	2	2	ZA3813 re-placed by ZA8724

January, 1945

(1)	(2)	(3)	(4)	(5)	(6)	(7)	(8)	(9)	(10)
ITEM No.	VAOS SEC.	MFRS. CODE	PIECE PT. OR Dwg. No.	CATALOGUE No.	DESIGNATION	SCH. OR ILL.No.	Mk.1	Mk.2	ISSUE IN LIEU
95.	Z1	A-17 } N-1 }	20942 } E245 pt. 1 }	ZA/3Z9858-8.31	SWITCH, toggle, SPST, 3 amp., 250-v., No. 3, U.S. type	X2	1	1	ZA3814
96.	Z1	C-6 } N-1 }	1529 } D947 pt. 6 }	*ZA/2Z9402.100	TERMINAL BOARD, bakelite, 2 contact, 1.1/8-in. lg. x 3/8-in. w. x 1/16-in. thk.		2	2	ZA11581
97.	Z1	C-6 } N-1 }	1520A } D947 pt. 5 }	*ZA/4C1668B/T13	TERMINAL BOARD (STRIPS tag) bakelite, 3 way, 1/8-in. lg. x 21/32-in. overall		1	1	ZN3022 will also replace ZN3021. ZA/2Z9405.45 only main-tained.
98.	Z1	N-1	SA-22-G	*ZA/2Z9405.45	TERMINAL BRUSH BOARD (BRUSHES), 5 contact, No. 1, U.S. type (Used also in place of terminal board, 4 contact)		1	1	
99.	Z1	C-6 } N-1 }	1513 } D947 pt. 2 }	*ZA/2Z9401	TERMINAL STRIP (STRIPS tag) bakelite, 2 contact, 1-1/4-in. lg. x 5/8-in. w. x 1/8-in. thk.		4	4	
100.	Z1	C-6 } N-1 }	1520 } D947 pt. 4 }	*ZA/2Z9402.37	TERMINAL STRIP, bakelite, 1.3/16-in. lg. x 3/8-in w. x 3/32-in. thk.		7	7	ZA12462
101.	Z1	C-6 } N-1 }	1531 } D947 pt. 8 }	*ZA/2Z9479.3	TERMINAL STRIP (STRIPS tag) bakelite, 4 contact, 1.9/16-in. lg. x 3/8-in. w. x 1/16-in. thk.		1	1	ZA19761
102.	Z1	N-1	SA-41H } SA-2493 }	ZA/2Z9644.10	TRANSFORMER, BFO, 456 Kc/s (when used on Rec. Set R106 Mk. 2, ZA/2C4529/2 must be fitted)	T-4	1	1	ZN3032
103.	Z1	N-1	SA-41F } SA-2492 }	ZA/2Z9641.82	TRANSFORMER, I.F., interstage, 456 Kc/s (when used on Rec. Sets R106 Mk. 2, ZA/2C4529/2 must be fitted)	T-2	1	1	ZN3035

(1)	(2)	(3)	(4)	(5)	(6)	(7)	(8)	(9)	(10)
ITEM NO.	VAOS SEC.	MFRS. CODE	PIECE PT. OR DWG. No.	CATALOGUE No.	DESIGNATION	SCH. OR ILL.No.	Mk.1	Mk.2	ISSUE IN LIEU
104.	Z1	N-1	SA-41G	ZA/229641.81	TRANSFORMER, I.F., output	T-3	1	1	ZN3034
105.	Z1			ZA/JAN/6B7	456 Kc/s		1		ZA5627
106.	Z1			ZA/JAN/6C6	TUBE (VALVES), type 6B7		3		ZA5625
107.	Z1			ZA/JAN/6D6	TUBE (VALVES), type 6C6		4		ZA5626
108.	Z1			ZA/JAN/6J7	TUBE (VALVES), type 6D6				
109.	Z1			ZA/JAN/6K7	TUBE (VALVES), type 6J7, (VT-91)			3	ZAL2629
110.	Z1			ZA/JAN/6SQ7	TUBE (VALVES), type 6K7, (VT-86)			4	ZAL2630
111.	Z1			ZA/JAN/6V6GT/G	TUBE (VALVES), type 6SQ7, (VT-103)			1	ZA3444
112.	Z1			ZA/JAN/42	TUBE (VALVES), type 6V6GT/G			1	ZAL7191
					TUBE (VALVES), type 42		1		ZAL7125

January, 1945

PACK, VIBRATOR, (VIBRA-PACK) 686S, COMPLETE (ZA 3986)

(1)	(2)	(3)	(4)	(5)	(6)	(7)	(8)	(9)
ITEM No.	VAOS SEC.	MFRS. CODE	PIECE PT. OR Dwg. No.	CATALOGUE No.	DESIGNATION	SCH. OR ILL. No.	No. OFF	ISSUE IN LIEU
1.	Z1	N-1	E337 pt. 3	ZA/3DB8-82	CAPACITOR, electrolytic, 2 section, 8 + 8 mf. +40%-10%, 475-v.D.C. wkg.	C-2 } C-3 }	1	
2.	Z1	N-1	E338 pt. 15	ZA/3DB500-13	CAPACITOR, electrolytic, 500 mf., 15-v.D.C. wkg.	C-1	1	
3.	Z1	N-1	SA-31B	ZA/3C326-31B	COIL, choke filter, 17 h. ±20%, 80 ma., 300 ohms, No. 2, U.S. type	L-1	1	
4.	Z1	N-1	SA-869	ZA/3C326-869	COIL, choke, R.F., 14 microhenries, ±2 watt	L-2 E-2 } E-3 }	1	
5.	Z1	N-1	E514 pt. 1 & 2	ZA/3Z1086B-1	CLIP, test, 25 amp., 2.27/32-in. x 5/8-in. overall		2	
6.	Z1	N-1	F135-6	ZA/3Z1921	FUSE, FU-21, 10 amp., 25-v., Littelfuse, No. 3AG	F-1	1	
7.	Z1	N-1	D827 pt. 1	ZA/3Z3275	FUSE POST, extractor, Littelfuse, No. 1075	X-2	1	
8.	Z1	N-1	E319 pt. 1	ZA/2Z8674.40	SOCKET (HOLDERS), tube, 4 prong, No. 4, U.S. type	X-1	1	
9.	Z1	N-1 } A-17 } H-20 }	D851 pt. 2 } 80994 } 150777 }	ZA/3Z9858-8.33	SWITCH, toggle, SPST, 3 amp., 250-v., No. 2, U.S. type	S-1	1	ZA8724
10.	Z1	N-1 } N-1 } N-1 }	E604 } HCLUG } F206 }	ZA/2C4529/T2	TERMINAL, screw, brass, electrical hd., No. 8-32 thd. x 1/4-in. with lug, cadmium plated	E-1	1	
11.	Z1	N-1		ZA/2C4903A/V1	VIBRATOR, 6.3-v., Mallory, type 826	K-1 V-1	1	
12.	Z1			ZA/JAN/6X5GT/G	TUBE (VALVES), 6X5GT/G		1	

January, 1945

POWER PLY UNIT, TYPE 697, COMPLETE (ZA/3HY 6-1)

(1)	(2)	(3)	(4)	(5)	(6)	(7)	(8)	(9)
ITEM No.	VAOS SEC.	MFRS. CODE	PIECE PT. OR DWG. No.	CATALOGUE No.	DESIGNATION	SCH. OR ILL. No.	No. OFF	ISSUE IN LIEU
1.	Z1	N-1 } S-8 }	E337 pt. 5 } D9053 }	ZA/3DB8-82.1	CAPACITOR, electrolytic, 3 section, 8-8 MF., 475-v.D.C. Wkg.	C-12, 13, 14	1	
2.	Z1	N-1	SA-13Q	ZA/3C326-31Q	COIL (CHOKES), filter, 17 h. ±20%, 80 MA., 300 ohms, No. 1, U.S. type	L-2	1	
3.	Z1	C-15 } N-1 }	150 } E544 pt. 1 }	ZA/6Z3156	CONNECTOR, 2 pt., 8 ft., 660 W., 250-v.	P-1	1	
4.	Z1	N-1	SA-1964	ZA/USA/2019	COVERS, dust, power supply unit 697		1	
5.	Z1	N-1	E375 pt. 1	ZA/USA/2020	PANEL. steel socket mounting, 6.15/16-in. x 2.9/32-in. x 19/64-in. h.		1	
6.	Z2	N-1	G824-4	ZB/6L18208-4.8P	SCREW, steel, binding hd., self-tapping, No. 8 x 1/4-in. parkerized		4	
7.	Z1	C-6 } N-1 }	X18 } E319 pt. 1 & 2 }	ZA/2Z8674.40	SOCKET (HOLDERS), tube, 4 prong, No. 4, U.S. type	X2, 3	2	
8.	Z1	N-1	F361	ZA/3Z9858-3.2	SWITCH, toggle, DPDT, No. 1, U.S. type	F-3	1	
9.	Z1	N-1	D851 pt. 2	ZA/3Z9858-8.33	(Change over for transformer from 110-v. to 230-v.) SWITCH, toggle, SPST, 3 amp., 250-v., No. 2, U.S. type	S-2	1	ZA8724
10.	Z1	N-1	SA-1130	ZA/2Z9608-7	TRANSFORMER, power, 115/230-v., 50/60 cycles	T-1	1	
11.	Z1			ZA/JAN/80	TUBE (VALVES), type 80 (1 in use; 1 spare)	D-2	2	

January, 1945

ELECTRICAL AND MECHANICAL
ENGINEERING REGULATIONS

COIL STAGE	FREQUENCY 50-100 Kc/s TYPE J	FREQUENCY 100-200 Kc/s TYPE H	FREQUENCY 180-430 Kc/s TYPE G	FREQUENCY 480-960 Kc/s TYPE F	FREQUENCY O-9 TYPE
AERIAL	AE. COIL 	AE. COIL 	AE. COIL 	AE. COIL 	AE. COIL
FIRST R.F. TRANSFORMER	HF1 2 	HF1 2 	HF1 2 	HF1 2 	HF1
SECOND R.F. TRANSFORMER	HF2 3 	HF2 3 	HF2 3 	HF2 3 	HF2
LOCAL OSCILLATOR	OSC 4 	OSC 4 	OSC 4 	OSC 4 	OSC 4

E-102
1-1002

FOR VALUES OF C36, 40, 44, 56 and 57, 8

Fig 1002 - Individual coil

	FREQUENCY 0.9-2.05 Mc/s TYPE E	FREQUENCY 1.7-4.0 Mc/s TYPE JD	FREQUENCY 3.5-7.3 Mc/s TYPE JC	FREQUENCY 7.0-14.4 Mc/s TYPE JB	FREQUENCY 14.0-30.0 Mc/s TYPE JA
AE. COIL					
HF1					
HF2					
OSC					

C36, 40, 44, 56 and 57, SEE TABLE 1002

Individual coil units